



AT AICS INSTALLATION AND OPERATION

Please ensure you read and fully understand this text before attempting any installation or maintenance. If you are unsure about any of the operations described below, the rifle should be taken to a competent gunsmith for assembly.

The Chassis has been designed to suit a Remington 700 barrelled action. **Please consult your Accuracy International dealer if you experience any difficulties during assembly.**

Note: All dimensions shown are in millimetres unless otherwise stated.



Before handling the rifle or attempting any operation, the individual responsible for the upgrade must ensure the safety of themselves and all others by:

- Standing behind the weapon
- Ensuring it is pointing in a safe direction
- Checking it is unloaded and safe to handle
- Removing the bolt

Note: ensure that the firearm is in a safe overall working condition prior to performing this upgrade

Parts List

1 x Chassis (Long or Short Action)
1 x 5 round detachable box magazine
1 x Rail Adaptor (Harris Bipod)
1 x 2.5mm hex key
1 x 4mm hex key
1 x Butt spacer screw kit

Optional Parts

Action Rail Assembly
Harris Bipod Assembly
Forend Rail kit
Forend Rail Assembly
Night Vision fitting kit

Tools Required

Torque wrench with a range of 0.8 - 6 Nm [7-53 in-lb], 3/16" hexagon insert

Tools for Optional Parts

2.5mm & 5mm hex key inserts for torque wrench
Torx 15 Key
Torx 15 inserts for torque wrench
Loctite 243 (blue) – For optional Action Rail only

SECTION 1 – ASSEMBLY

Preparation of the Action and Barrel

- Ensure that the rifle is unloaded and is safe to handle.
- Remove the scope, scope mount and action rail (if required) from the action.
- Remove the Barrel and Action from its existing stock by removing the two $\varnothing 1/4$ " Action screws.
- Ensure that the donor barrelled action is assembled correctly, e.g. the two trigger retaining pins are not protruding beyond the diameter of the action body, the recoil lug is correctly orientated and the barrel is properly fitted.
- If fitting an Action Rail: Align the Action Rail to the Action. Apply Loctite 243 to the threads of the four action rail fixing screws. Use a Torx T15 key to tighten each screw to 1.7Nm [15 in-lb].

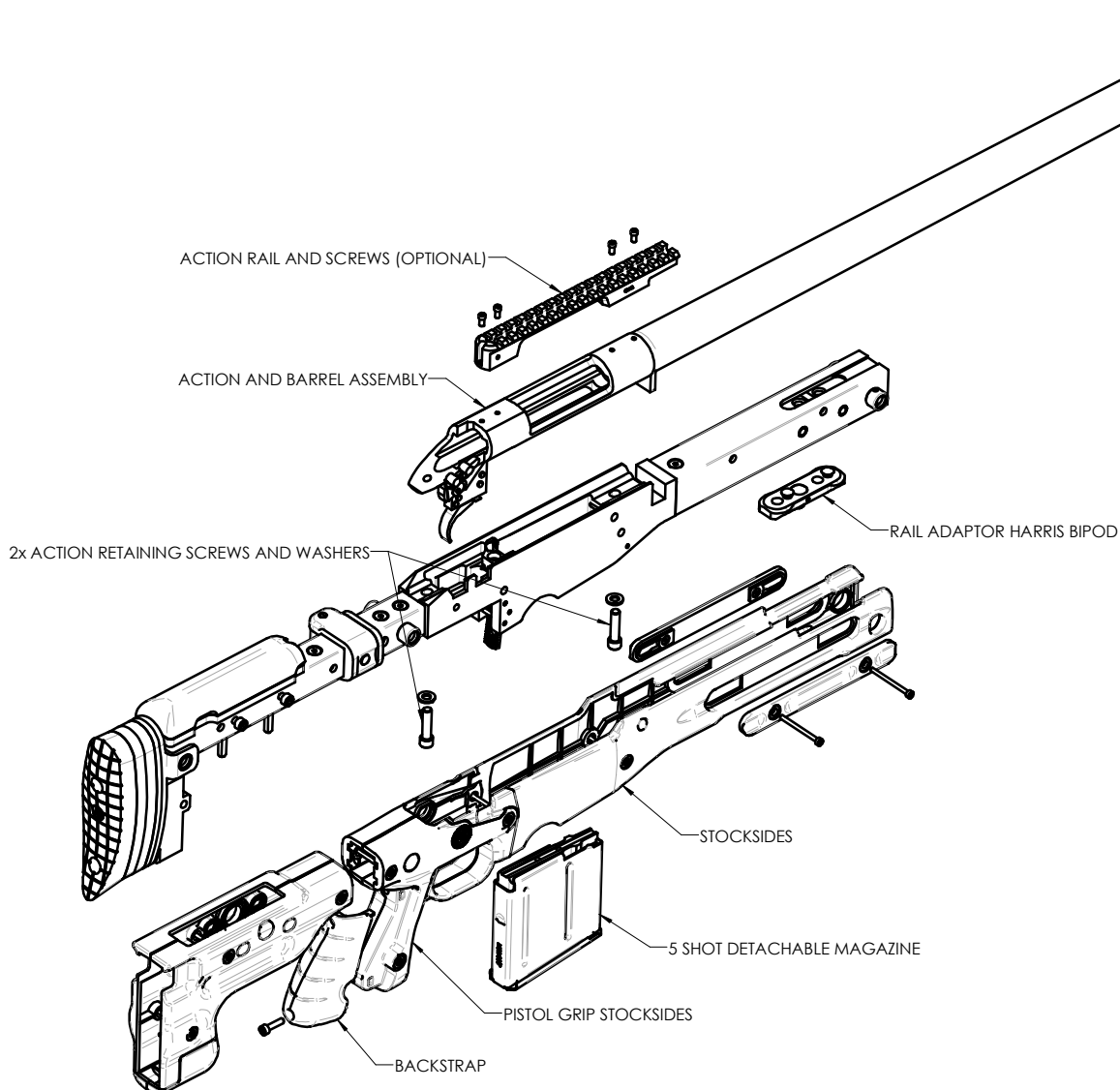

Parts identification diagram

Assembly of the Chassis and Barrelled action

- Remove the magazine from the AT AICS Kit if fitted.
- Carefully insert the barrelled action into the chassis. Partially engage the two Action retaining screws' threads into the action.
- Pull the action back until the recoil lug rests up against the chassis, then use a 3/16" (4.5mm AF) hexagon key to carefully tighten the action screws. Starting with the front screw lightly tighten both screws until the action is sitting in the 'V' of the chassis and is centred. Rotate the action until the trigger is correctly orientated.
- Using a torque wrench fitted with a 3/16" hexagon insert, tighten the action screws (starting with the forward screw), to the specified torque of 6 Nm [53 in-lb].



ENSURE THAT THE BOLT, TRIGGER AND THE SAFETY MECHANISM OPERATE CORRECTLY BEFORE USING THE RIFLE.

SAFETY

The rifle is now assembled and ready for optics to be mounted.



It is recommended that the user fires a five shot group, then re-tightens the action screws to the specified torque of 6 Nm [53 in-lb] to account for any 'settling in' before shooting a second five shot group and zeroing the optics to the rifle.

CAUTION

It is recommended that the torque of the two action screws is periodically checked.

SECTION 2 – USER ADJUSTABLE AND CONFIGURABLE FEATURES

Rail Fitting

The AT series of rifles and chassis systems can be fitted with an optional STANAG/MIL STD accessory Rail. Ensure the rifle is unloaded and is safe to handle. The forward stockside knockouts are removed and replaced with a keyhole slot interface kit:

- Loosen and remove the two M3 stockside screws.
- Remove the knockout panel from both sides.
- Fit the two interface plates, ensuring the orientation features are correctly aligned in the corresponding stockside pockets.
- Fit the two M4 CSK screws and tighten to 2Nm [17in-lb].
- A rail assembly can now be attached to either side of the rifle forend.

To remove a rail:

- Remove any accessories fitted to the rail.
- Apply thumb pressure to the rail and use the 4mm Hexagon key to loosen the securing fixings (turn anti-clockwise) until light resistance is felt (then stop, do not continue to undo).
- Slide the rail to the rear of the keyhole slots (open end) until it stops.
- Lift the rail clear of the chassis.

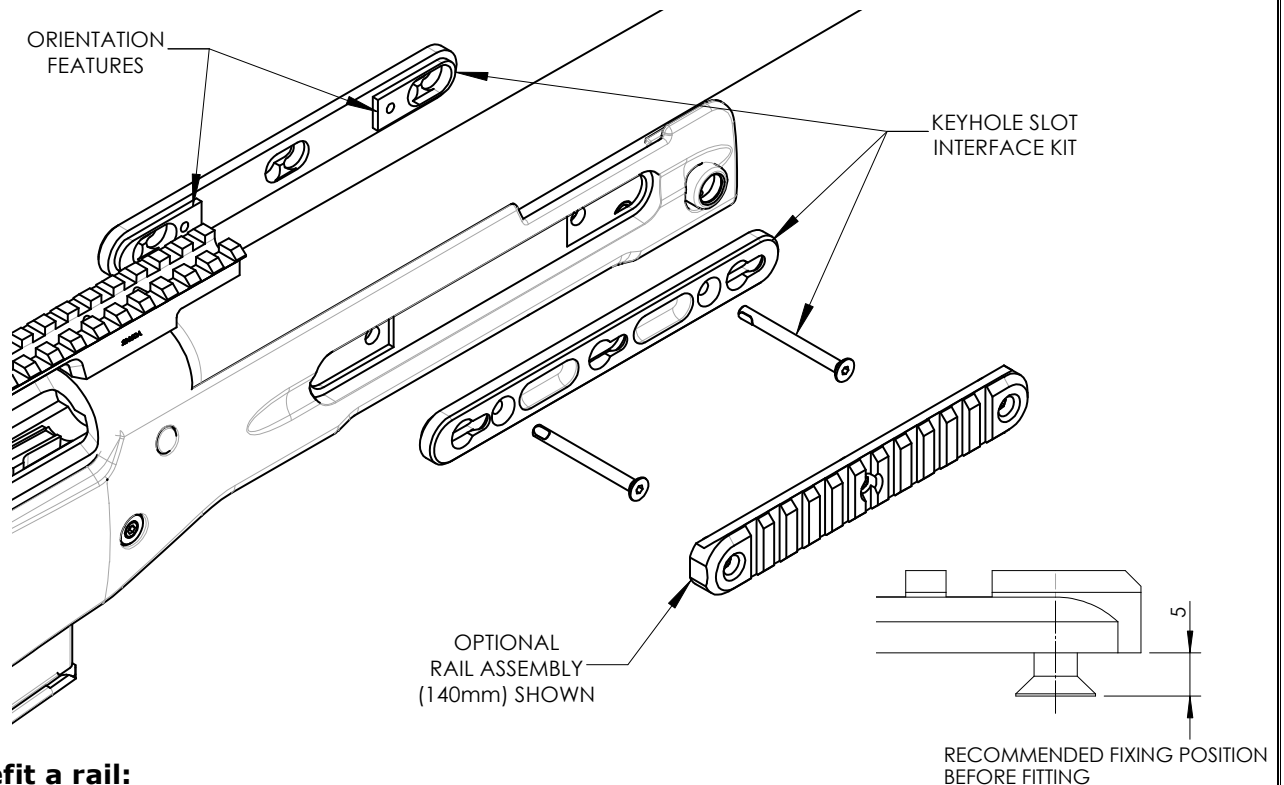

To refit a rail:

- With the retaining screws in the extended position shown, position the screw heads over the open end of the desired keyhole slots.
- Place the heads of the screws through the open end of the keyhole slots.
- Slide the rail forward until it comes to a stop at the closed end of the keyhole slots.
- Pull the rail upwards and tighten the retaining screws.
- Use a 4mm Hex key to tighten the securing fixings to a recommended torque of 4Nm [35 in-lb].
- The position of the Accuracy International Harris Bipod rail adaptor can be adjusted in the same way.

Night Vision Bracket kit fitting

The AT series of rifles and chassis can be fitted with an optional Night vision bracket kit. Ensure the rifle is unloaded and safe to handle.

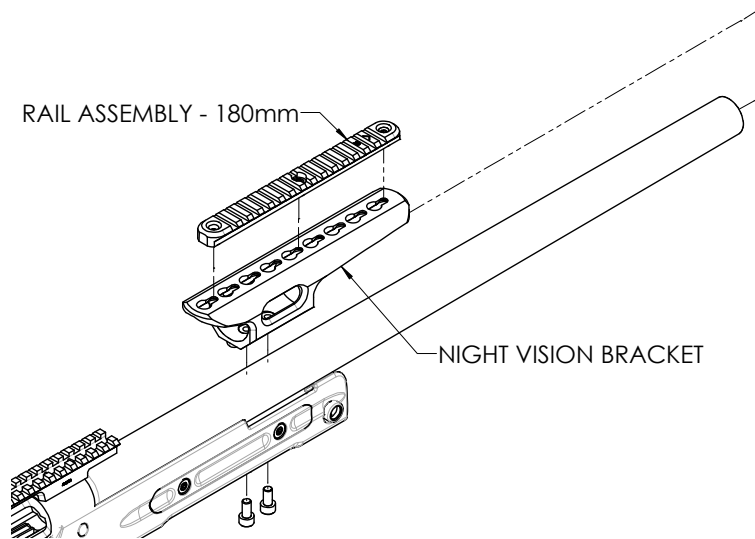

- Remove any rail or accessory from the underside of the forend that may prevent access to the two fixing screw holes.
- Slide the night vision bracket over the barrel and locate it in the pocket within the forend.
- Attach the Night Vision bracket to the forend using two M6 screws (supplied). Use a 5mm hex key to tighten each screw to 3.5Nm [31 in-lb].
- The night vision bracket is compatible with Accuracy International 80mm, 140mm and 180mm STANAG/MIL-STD rails and should be fitted in accordance with the rail fitting instructions in this manual.

Cheekpiece Adjustment

Ensure the rifle is unloaded and is safe to handle.

If vertical adjustment is required:

- Loosen the two vertical adjustment screws.
- Adjust the height of the cheek piece to the desired position and retighten the two vertical adjustment screws.

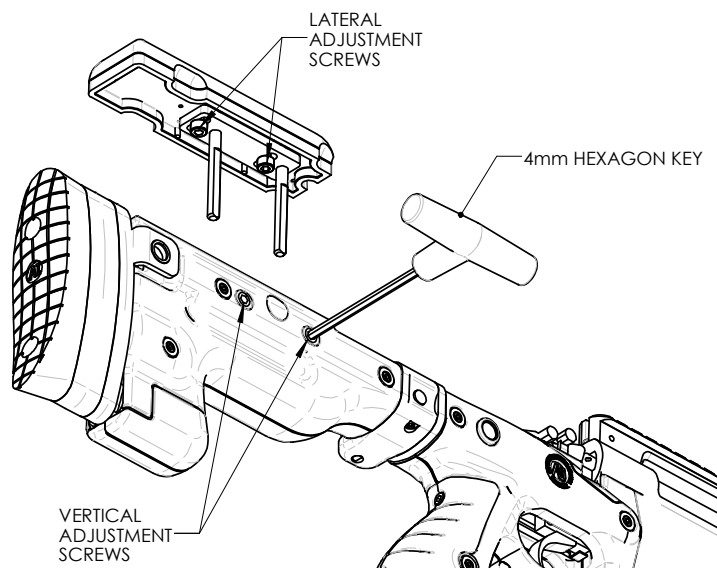

If lateral adjustment is required:

- Loosen the vertical adjustment screws and remove the Cheekpiece / Platform assembly from the Butt sub-frame.
- Loosen the lateral adjustment screws, adjust the Cheekpiece and retighten the screws.
- Replace Cheekpiece platform assembly in the Butt sub-frame, adjust the Cheekpiece to the desired height and retighten the screws.

To lower the Cheekpiece further, the 10mm spacer can be removed. To do this loosen and remove the lateral adjustment screws, remove the spacer and replace the screws with the supplied M5x12mm long screws.

Folding the Chassis

To fold the chassis:

- Depress and hold the Hinge catch.
- Fold the Butt assembly through 180 degrees to the left until the Female Catch engages with the Male Catch fitted on the front chassis.

To unfold the chassis:

- Firmly pull the Butt assembly from the front chassis and rotate through 180 degrees to the left to engage the hinge catch.
- Ensure the butt assembly is securely locked in position.

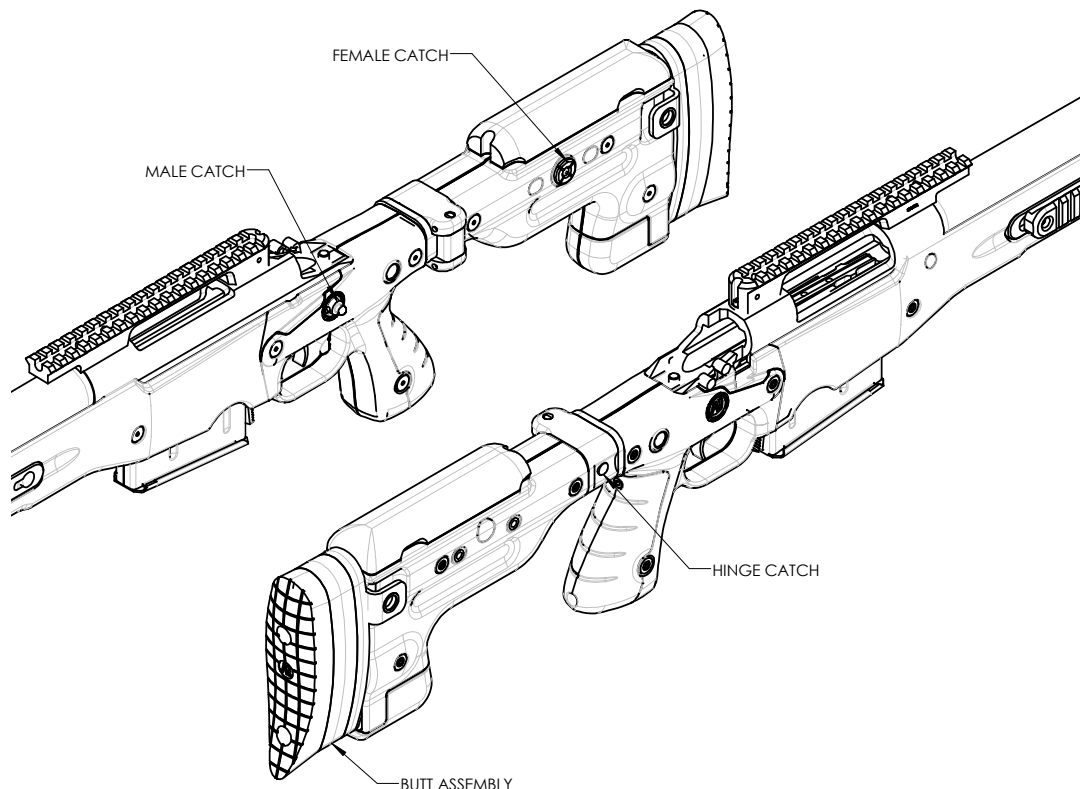

Adjusting Length of Pull

The length of pull of the system can be adjusted by removing or adding butt spacers. If spacers are removed, ensure the correct length screws are used to ensure the rear assembly is not damaged upon re-assembly. The AT AICS kit is supplied with a 4mm hex key and a set of different length screws to facilitate the use of 10mm spacer, 20mm spacer, 10+20mm spacers or no spacers (M6x25, M6x35, M6x45 or M6x16 respectively).

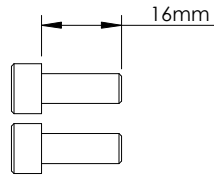

No spacers fitted

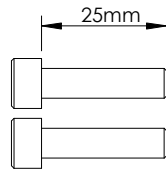

1 x 10mm spacer

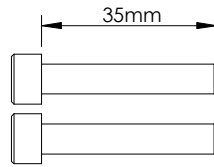

1 x 20mm spacer

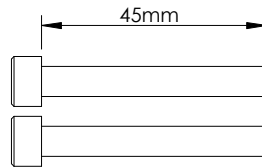

1 x 10mm and 1 x 20mm spacer

Screw Selection Guide

Accessories

The AT AICS kit can be easily upgraded by the user. A number of different upgrade modules and spare parts are available direct from Accuracy International or your local Accuracy International dealership.

Accuracy International of North America Inc.

Fredericksburg, VA, USA.
Tel + 1 540 368 3108
Fax + 1 540 368 3109
Email: aina@accuracyinternational.us

Accuracy International (UK) Ltd.

Portsmouth. UK.
Tel + 44 (0) 23 92 67 1225
Fax + 44 (0) 23 92 69 1852
Email: ai@accuracyinternational.org

www.accuracyinternational.com