



(19) **United States**
(12) **Patent Application Publication**
Dextraze et al.

(10) **Pub. No.: US 2012/0047786 A1**
(43) **Pub. Date: Mar. 1, 2012**

(54) **MODULAR FIREARM STOCK SYSTEM**

Publication Classification

(76) Inventors: **Serge Dextraze**,
St-Jean-sur-Richelieu (CA); **Sylvain Morin**,
St-Jean-sur-Richelieu (CA); **Emmanuel St. Pierre**,
St-Bruno-de-Montarville (CA); **Christian Vallieres**,
St-Nicholas (CA); **Ghyslain Durand**,
St-Jean-sur-Richelieu (CA); **Michael Brent Jarboe**,
Rineyville, KY (US); **Gregory Phillip Paradat**,
Lakewood, WA (US); **Gregory A. Dennison**,
Louisville, KY (US)

(51) **Int. Cl.**
F41C 7/00 (2006.01)
F41A 21/12 (2006.01)
F41C 27/00 (2006.01)
F41C 23/04 (2006.01)
F41A 11/02 (2006.01)
(52) **U.S. Cl.** **42/18; 42/71.01; 42/16; 42/17**

(21) Appl. No.: **13/184,501**
(22) Filed: **Jul. 16, 2011**

Related U.S. Application Data

(63) Continuation of application No. 12/640,531, filed on Dec. 17, 2009.

(57) **ABSTRACT**
A modular firearm is disclosed. The firearm that can be configured to operate using ammunition of different calibers via interchangeability of only a few parts. The firearm includes a foldable butt stock assembly for quickly and easily converting the firearm from an extended operating configuration to a compact transport configuration, and vice-versa. Additionally, the firearm includes a modular hand guard assembly having multiple mounting platforms for accommodating a variety of different accessories.

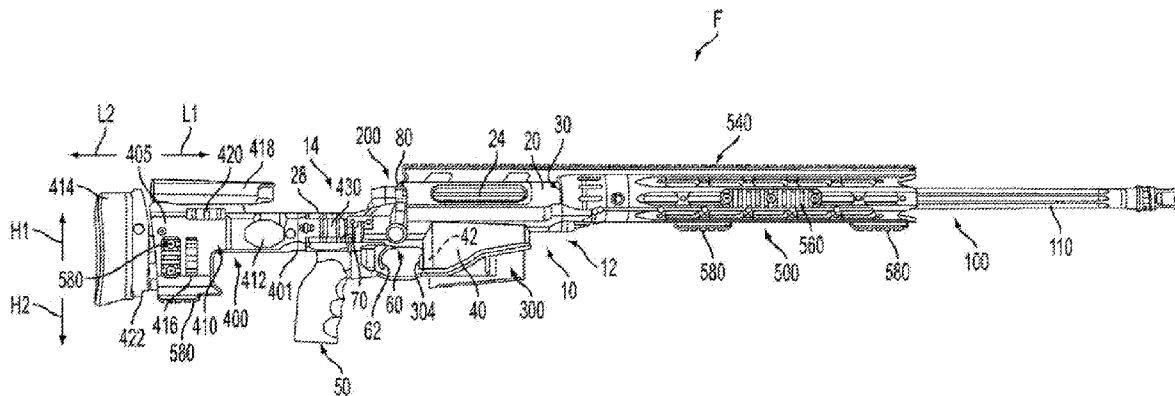

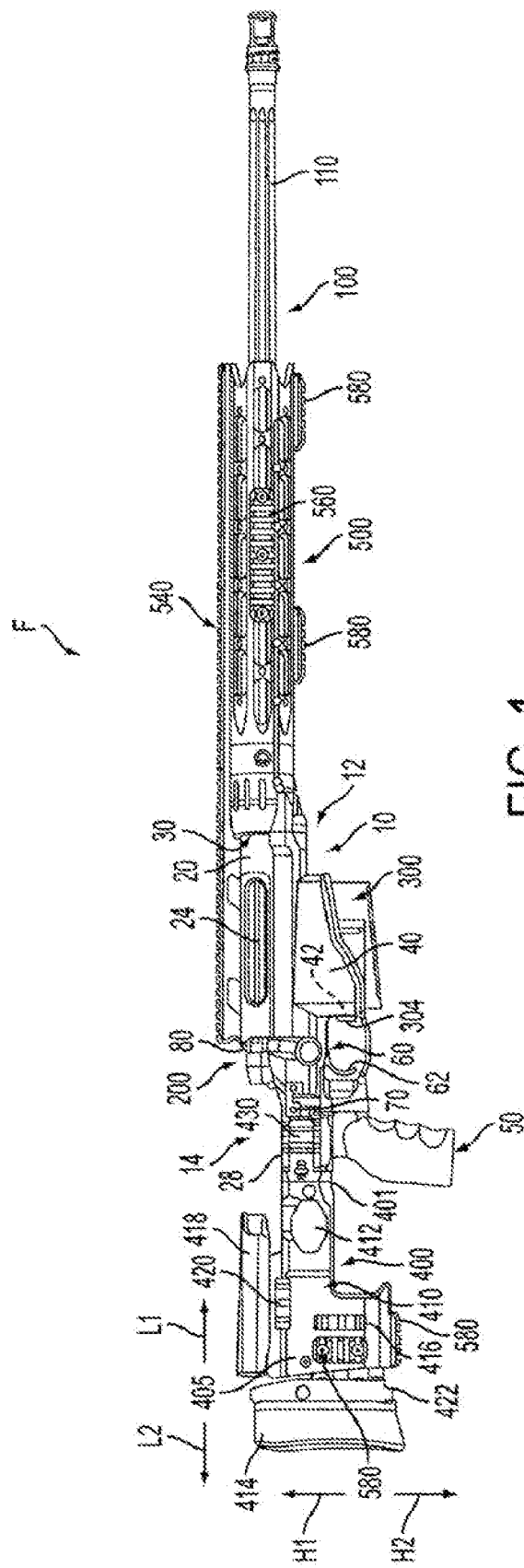

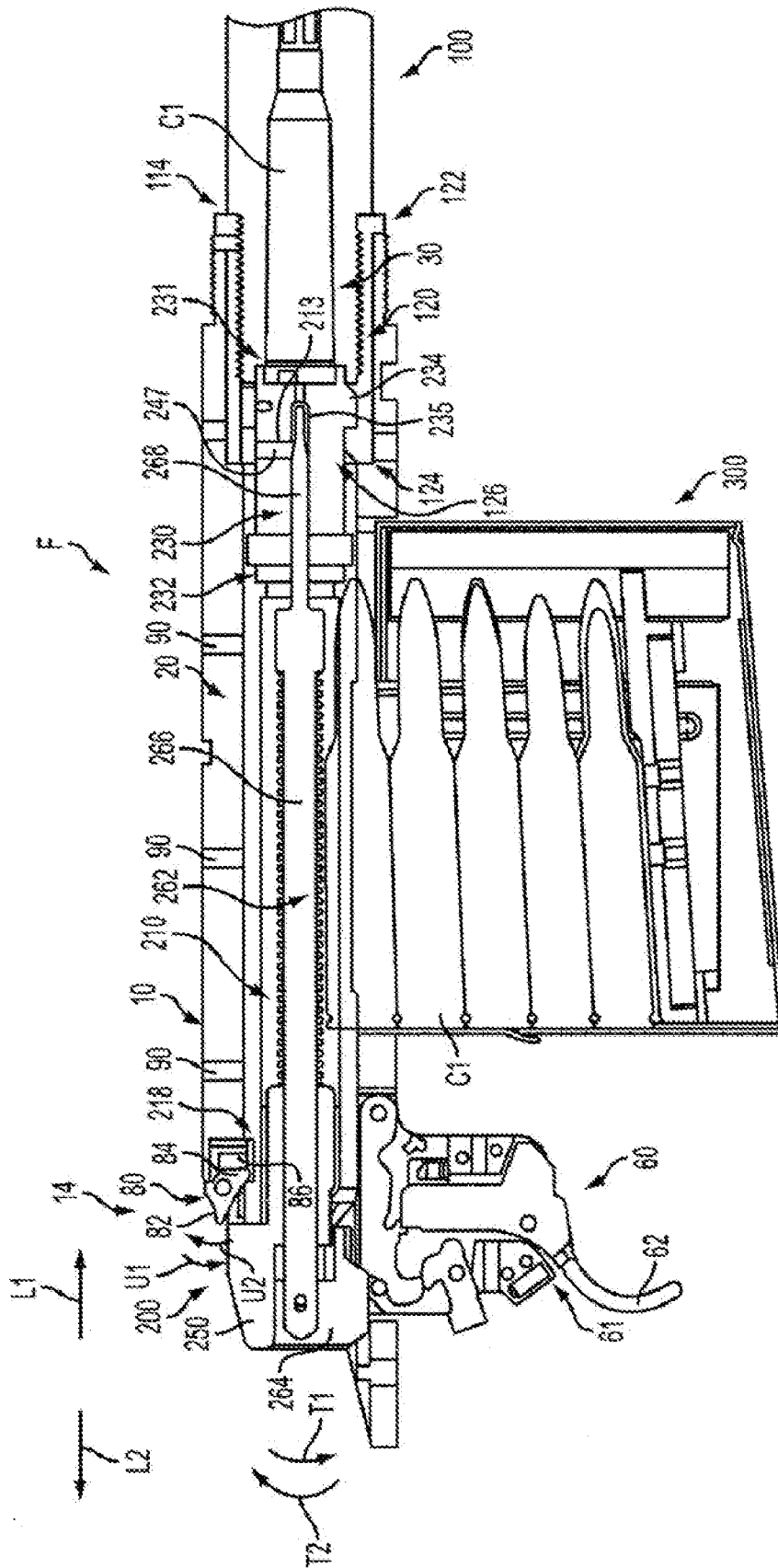

FIG. 2

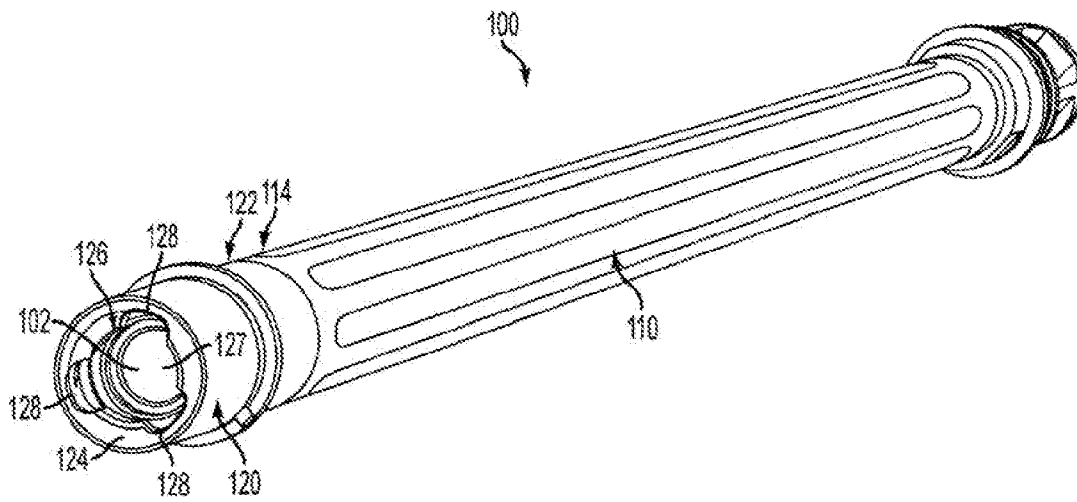

FIG. 3

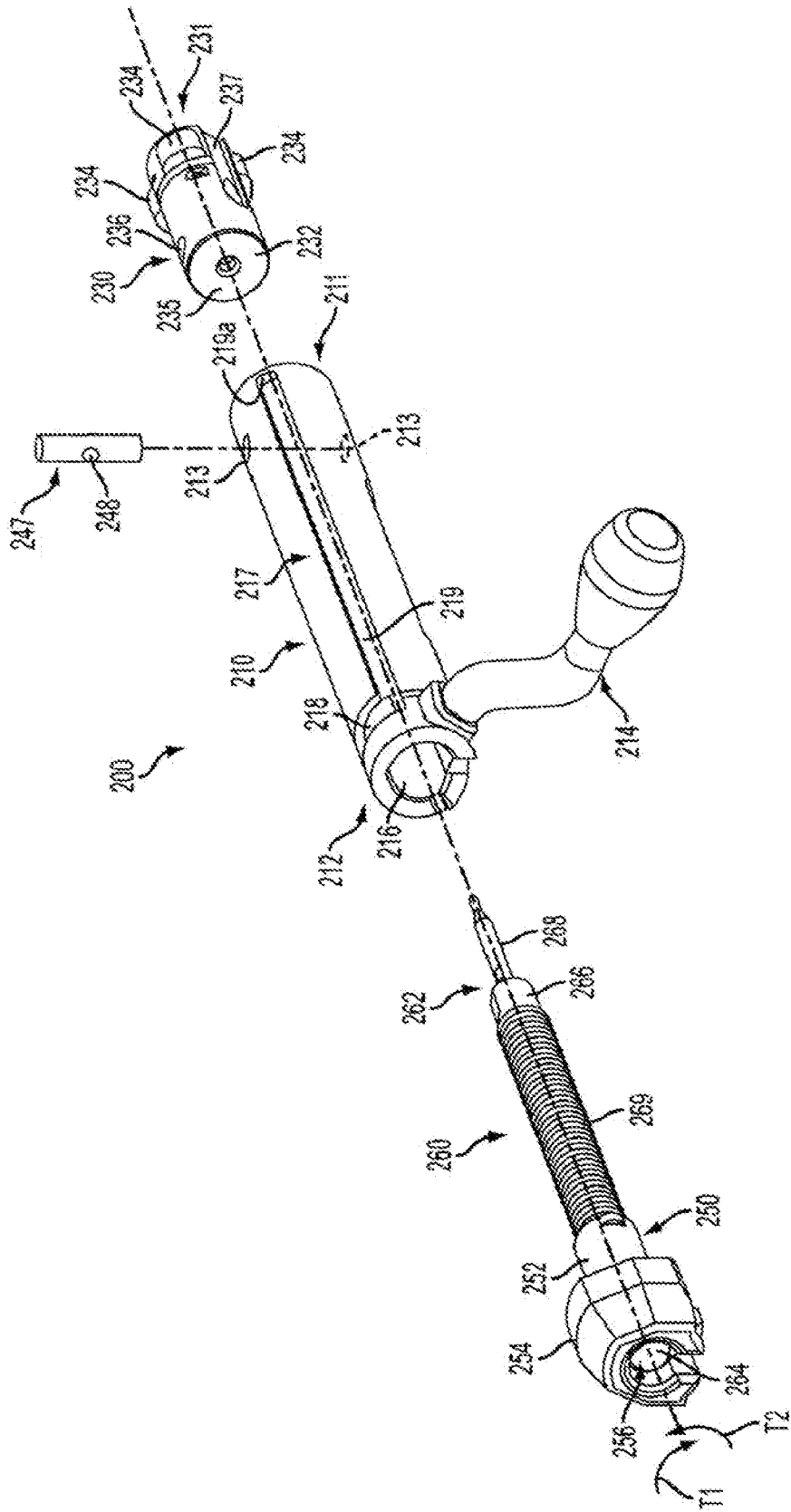

FIG. 4

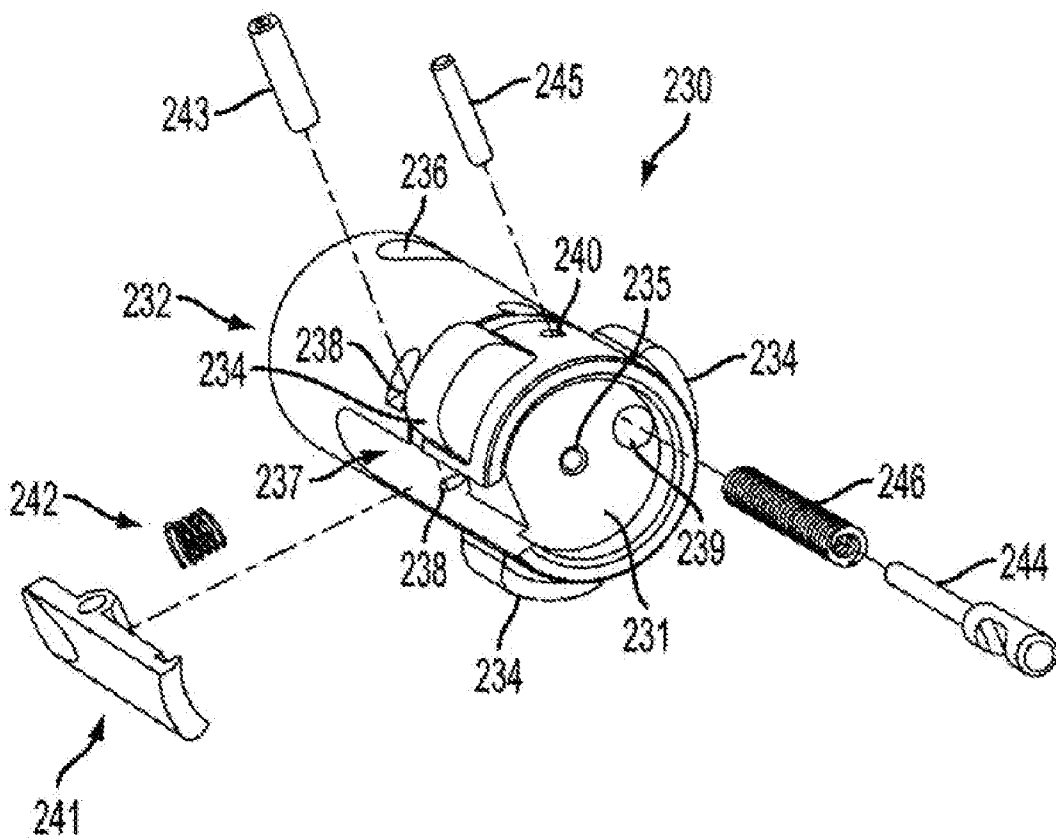

FIG. 5

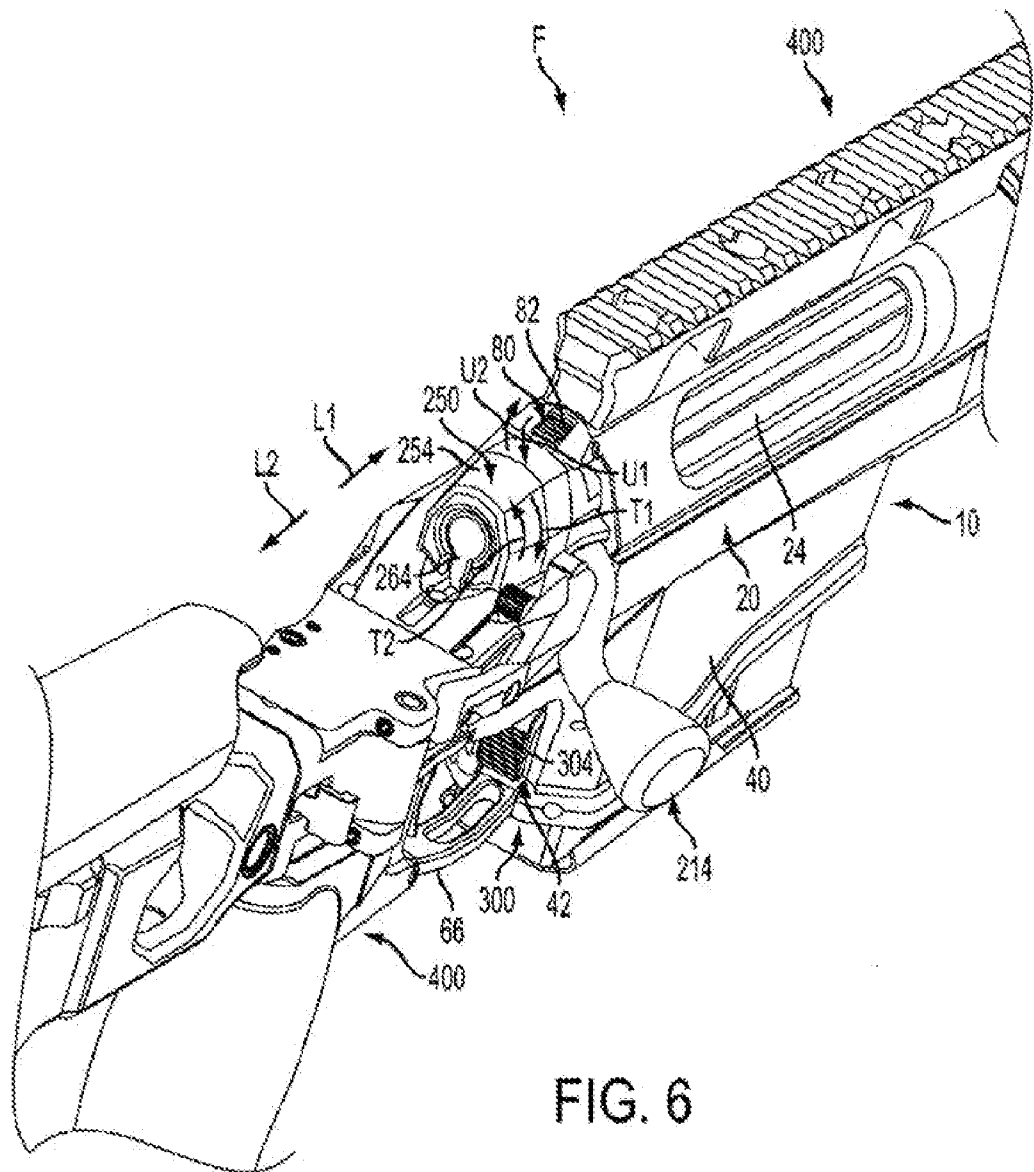

FIG. 6

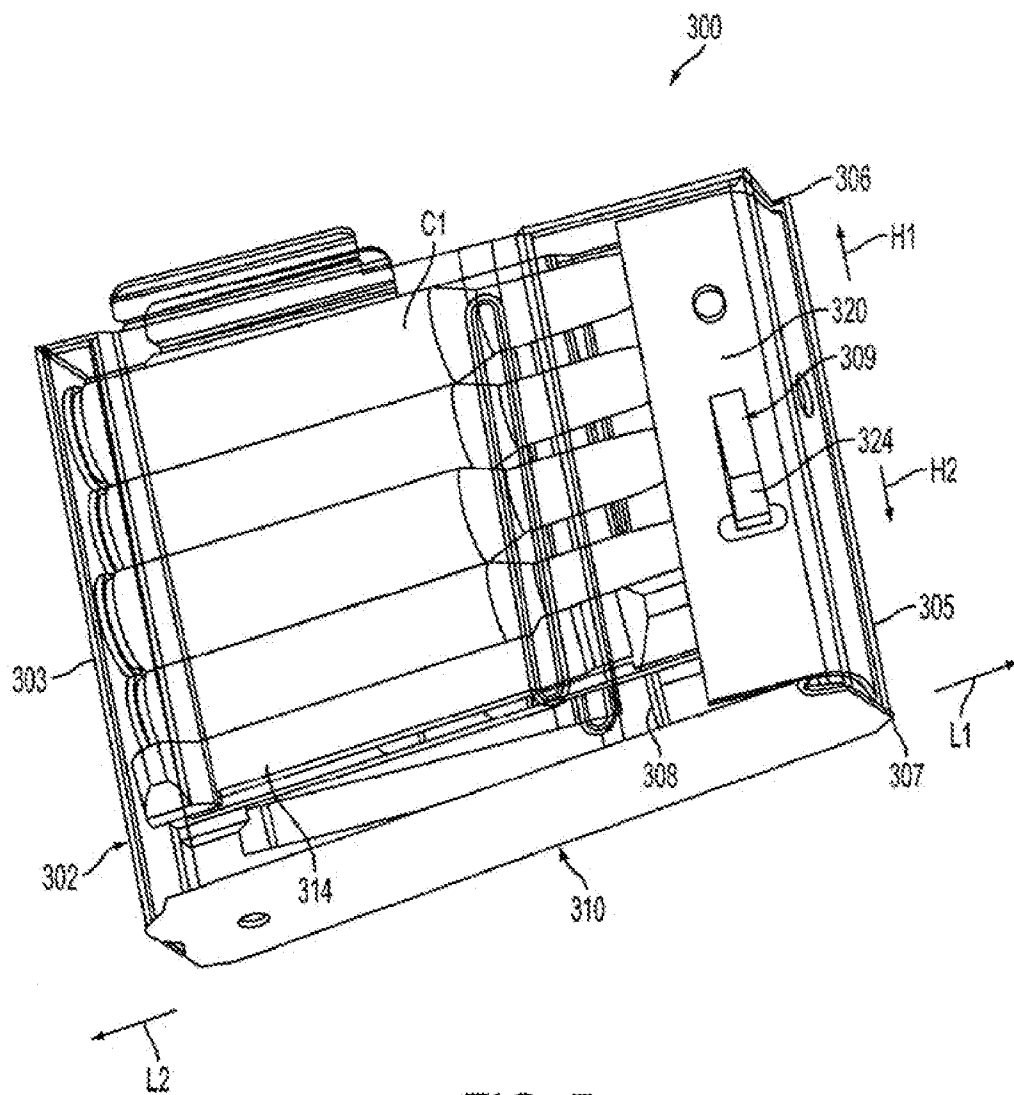

FIG. 7

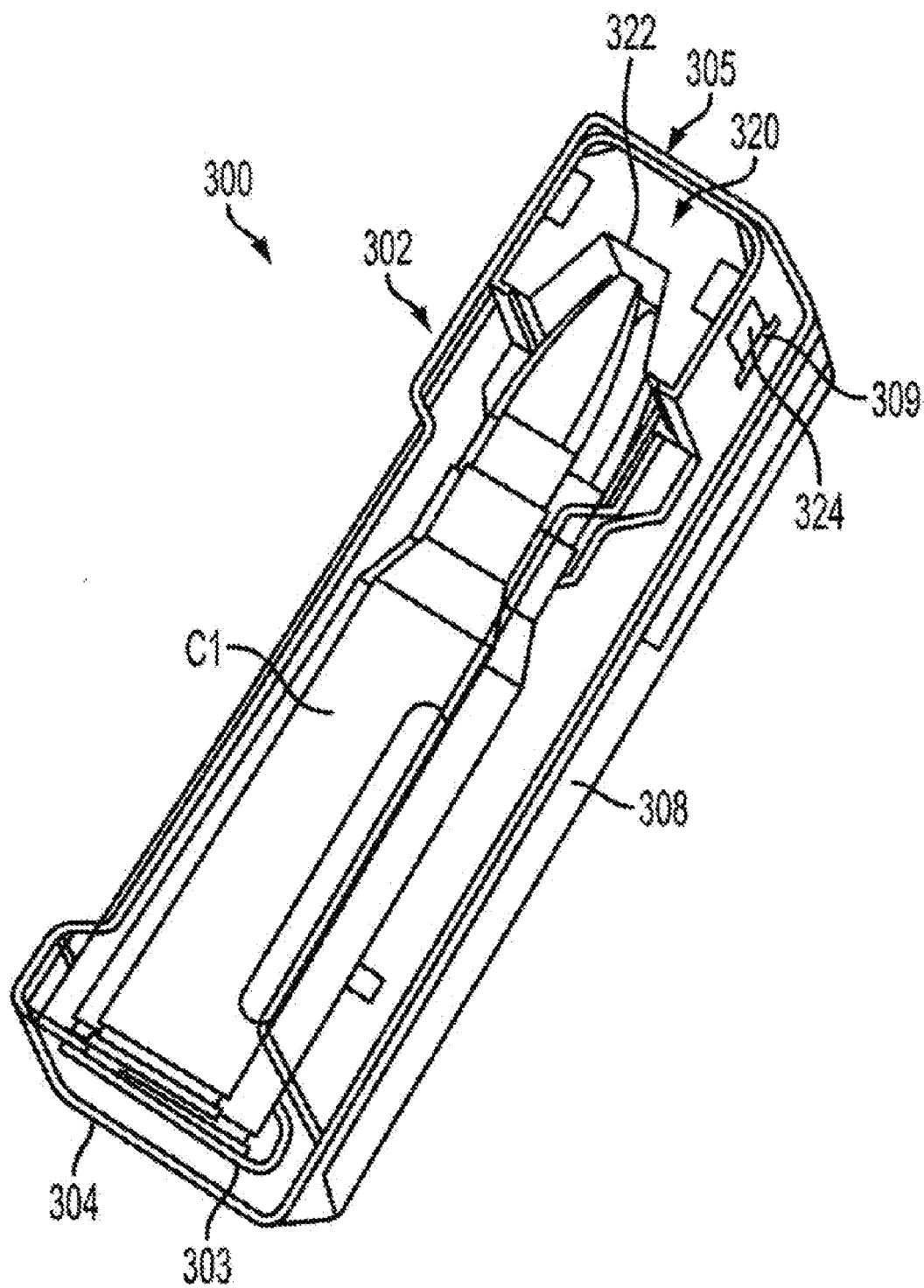

FIG. 8

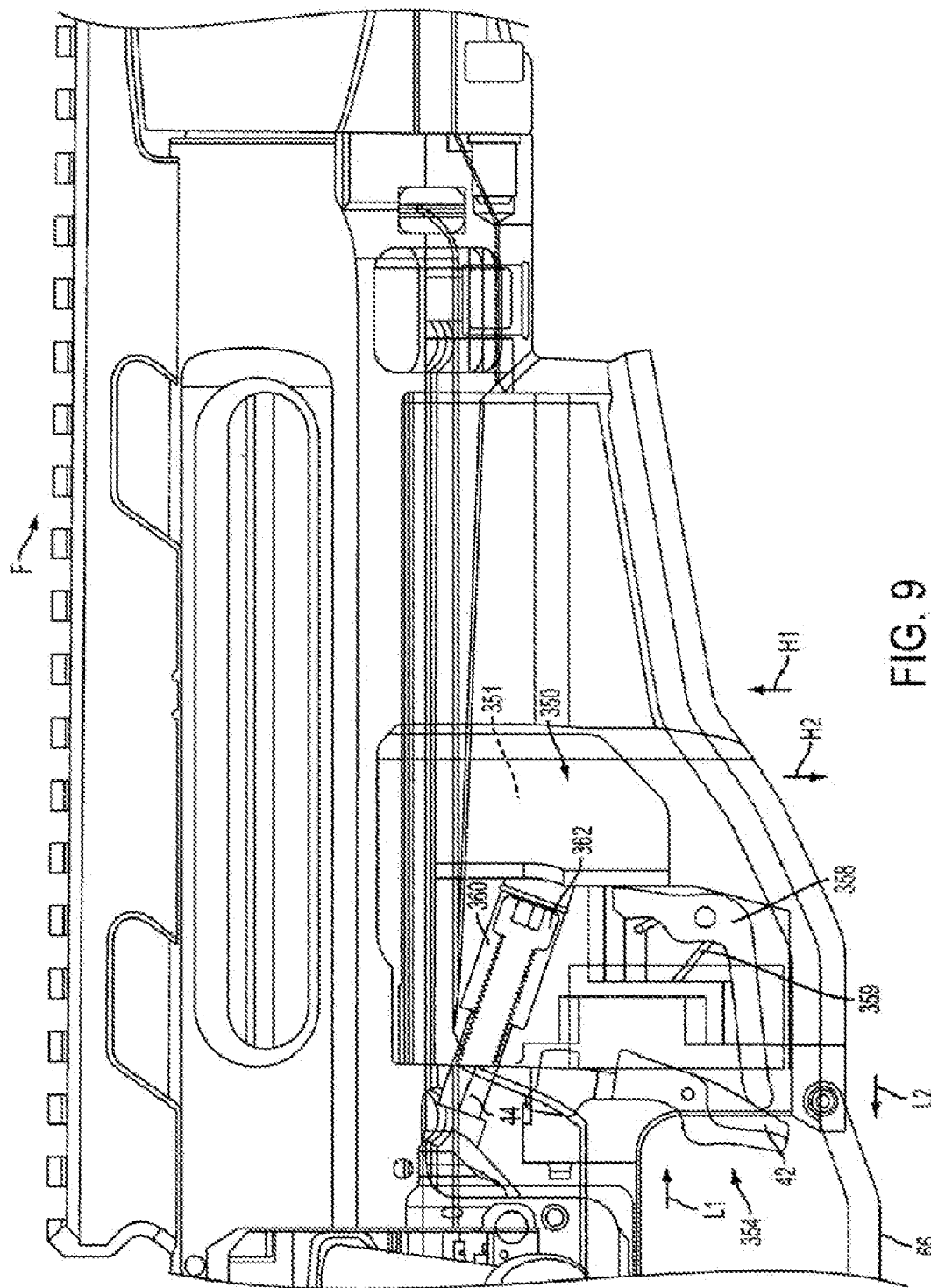

FIG. 9

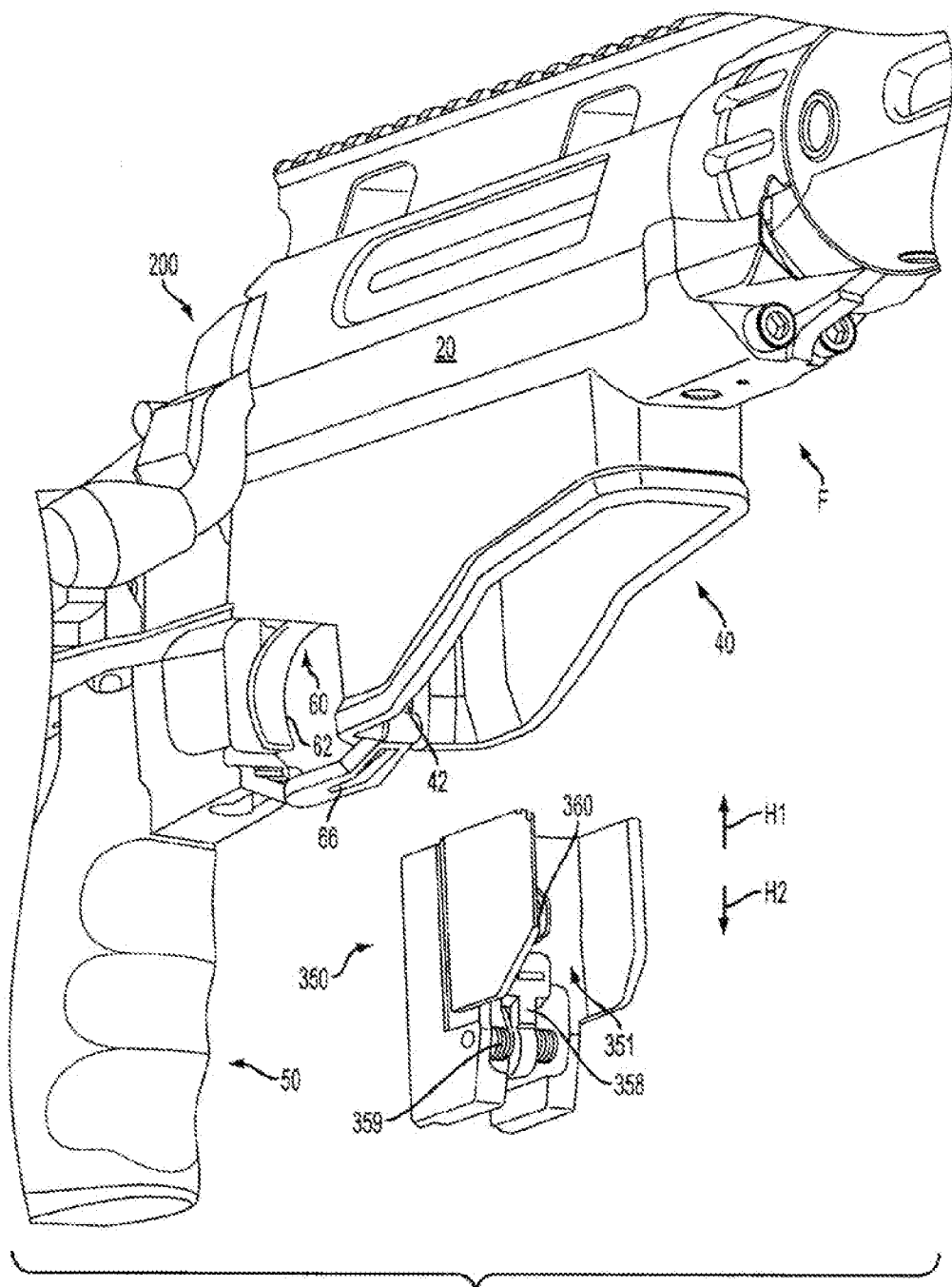

FIG. 10

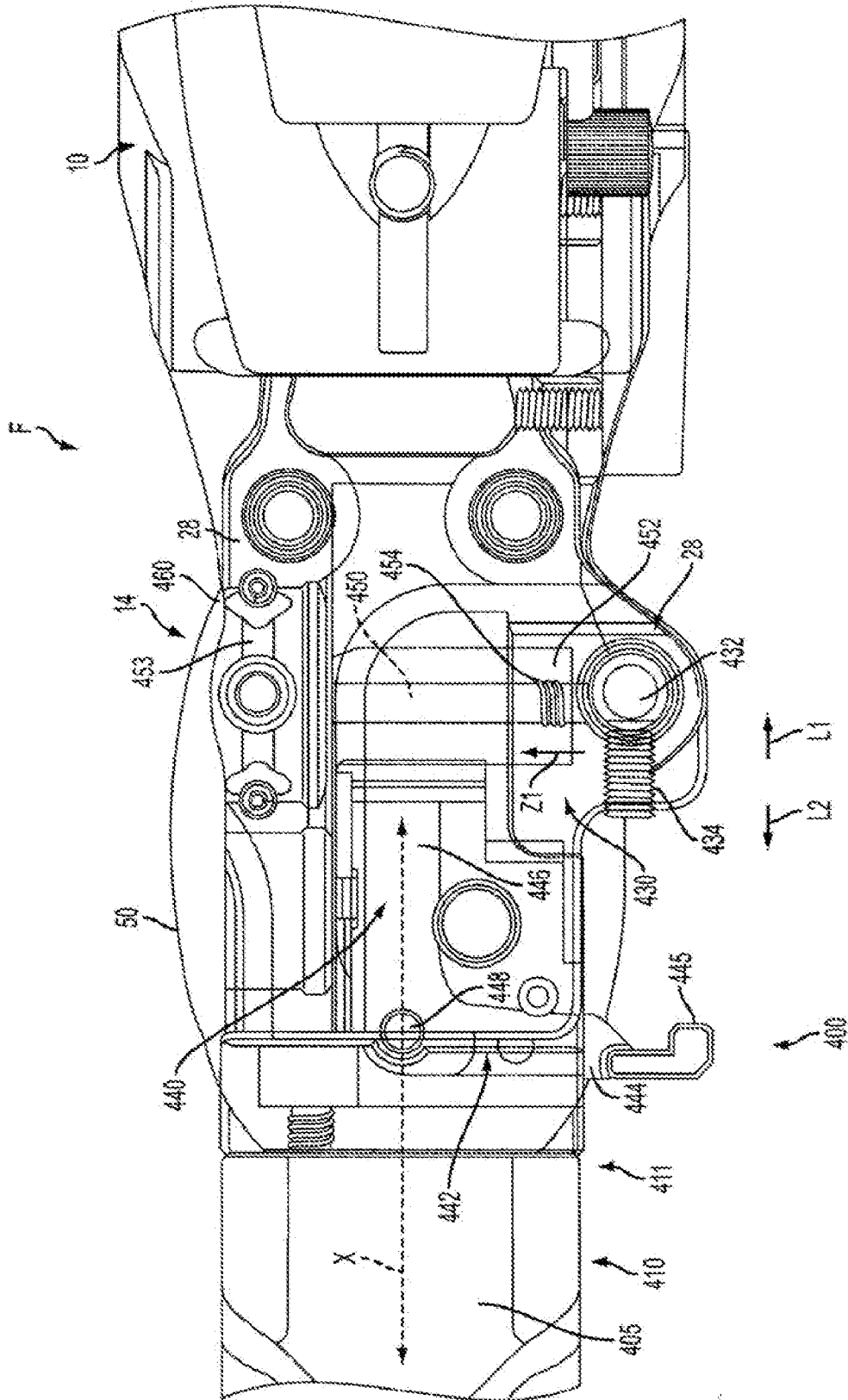

FIG. 11A

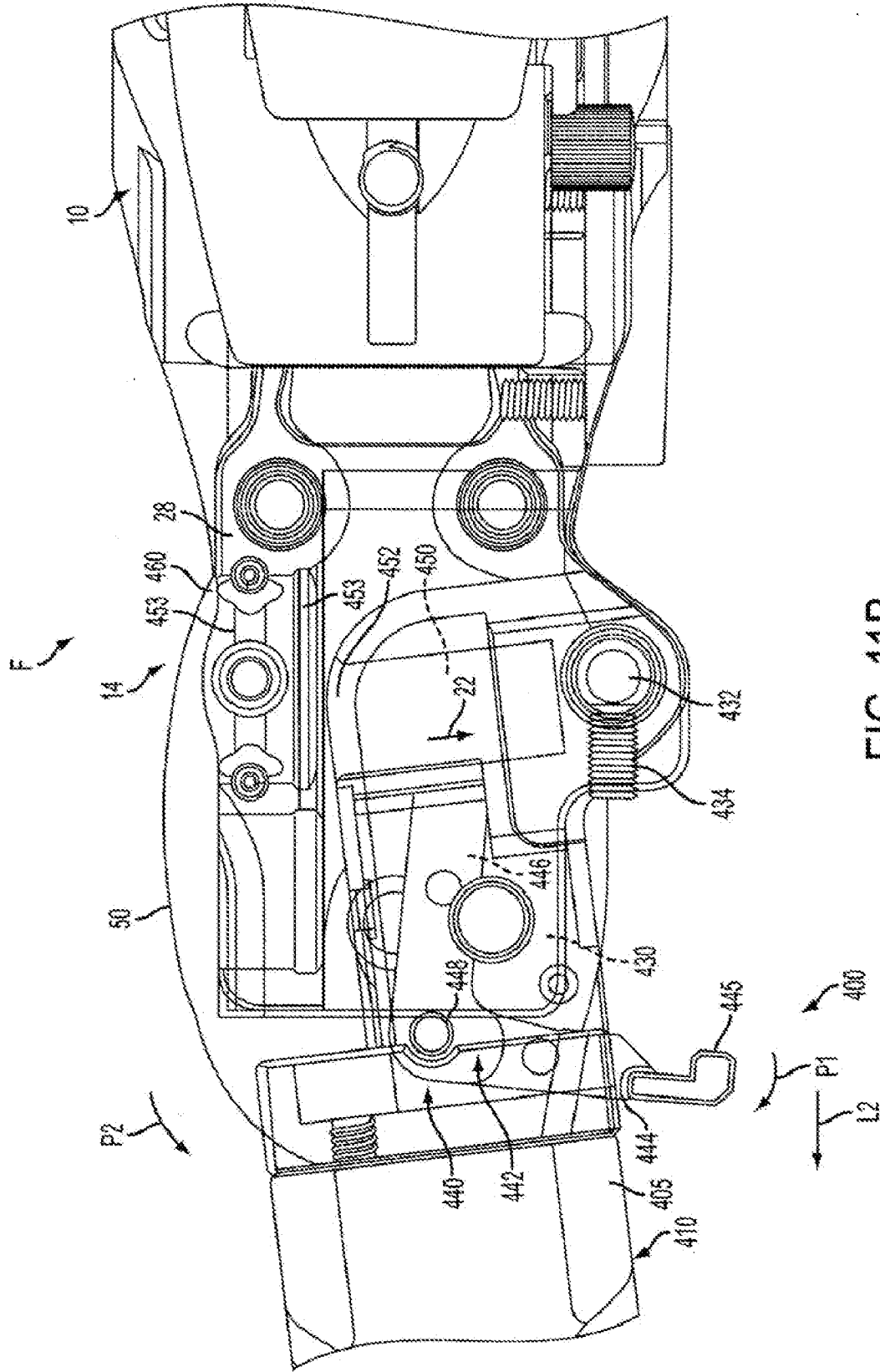

FIG. 11B

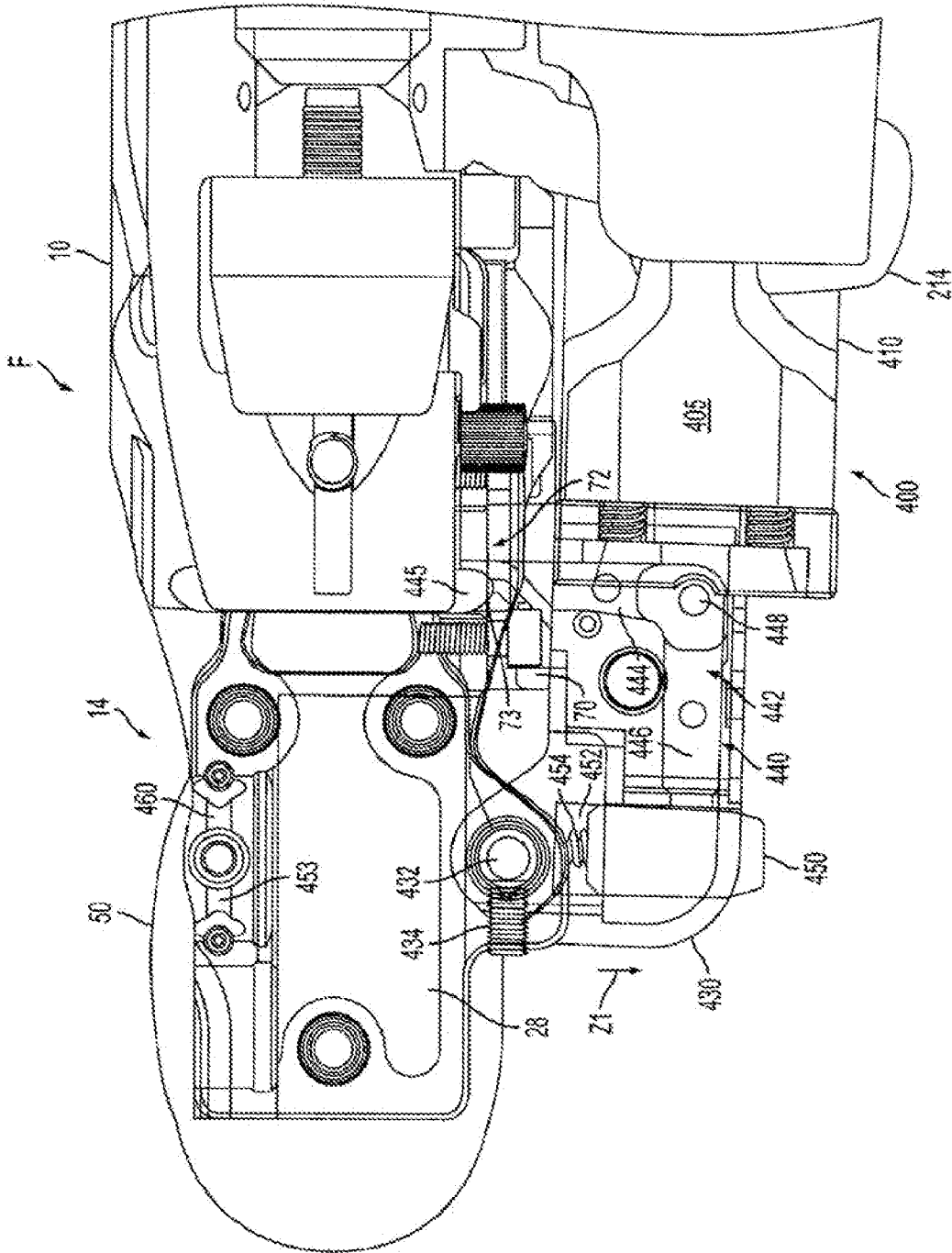

FIG. 11C

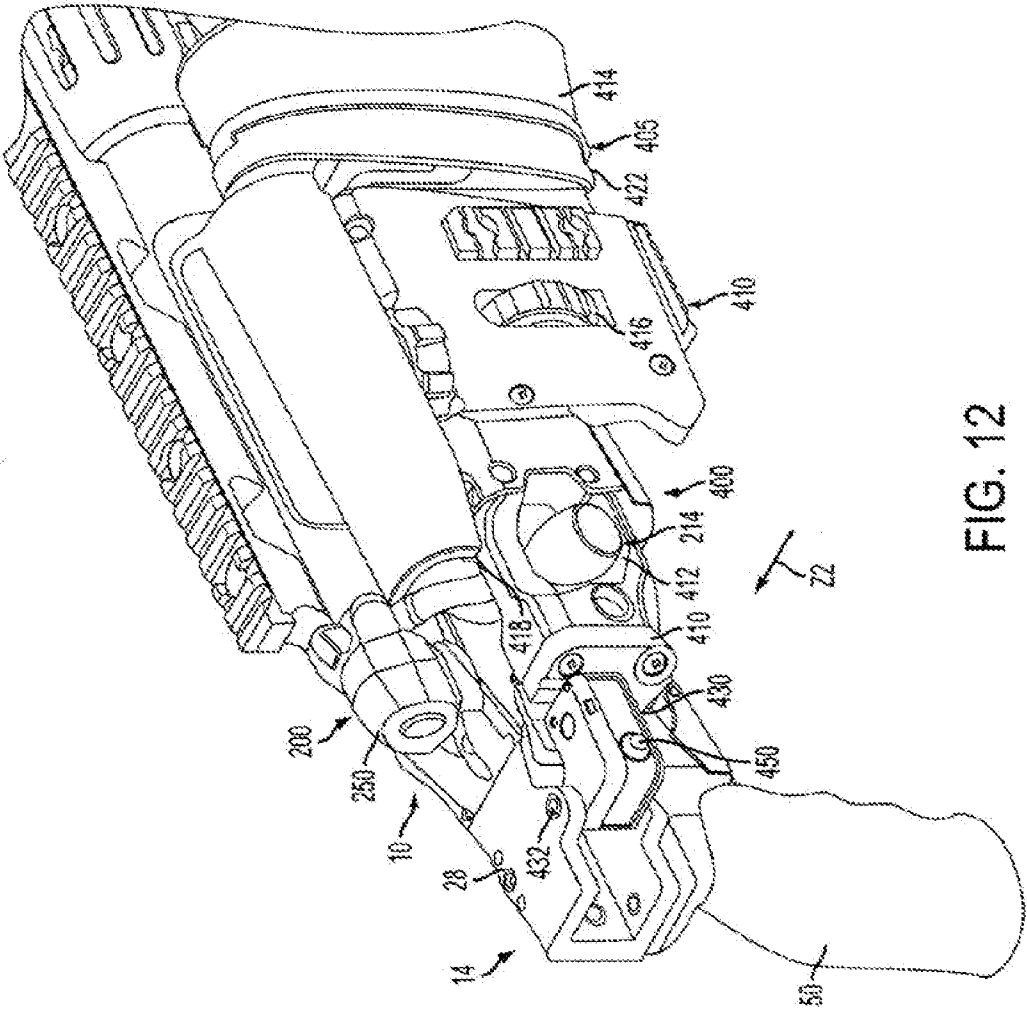

FIG. 12

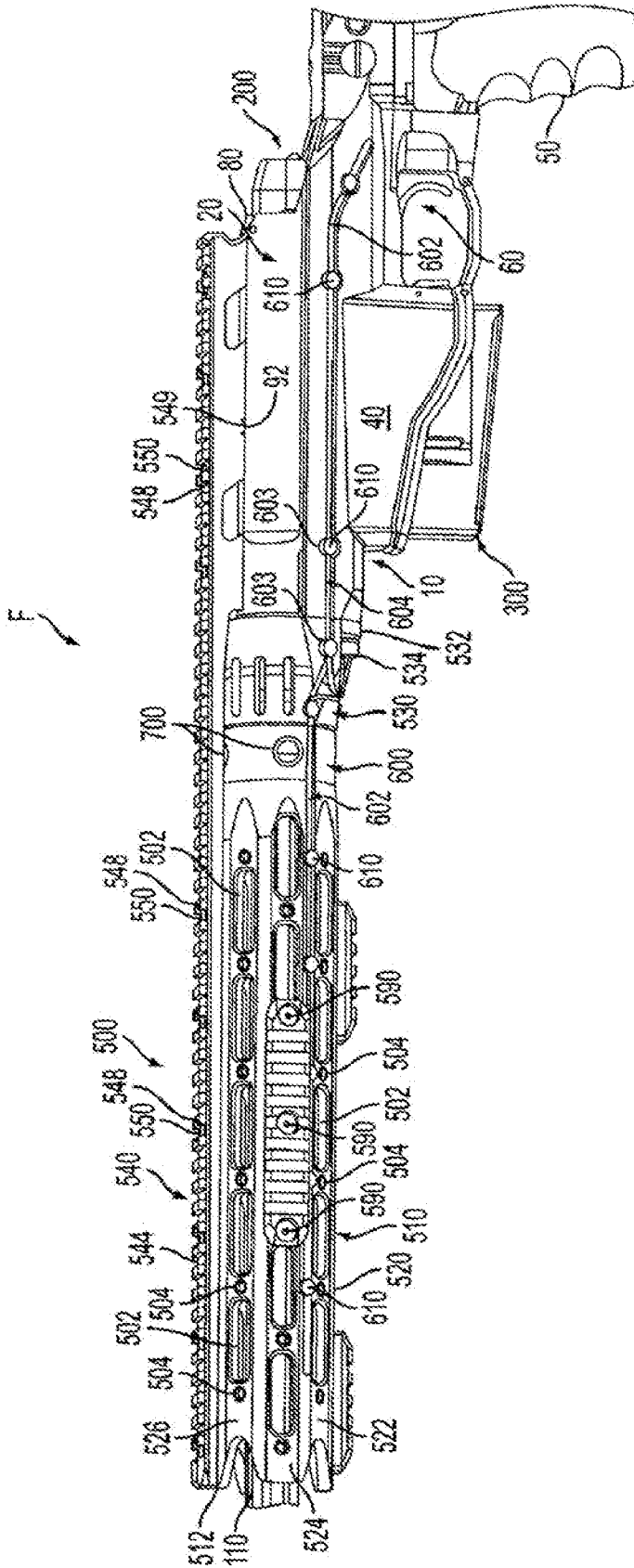

FIG. 13

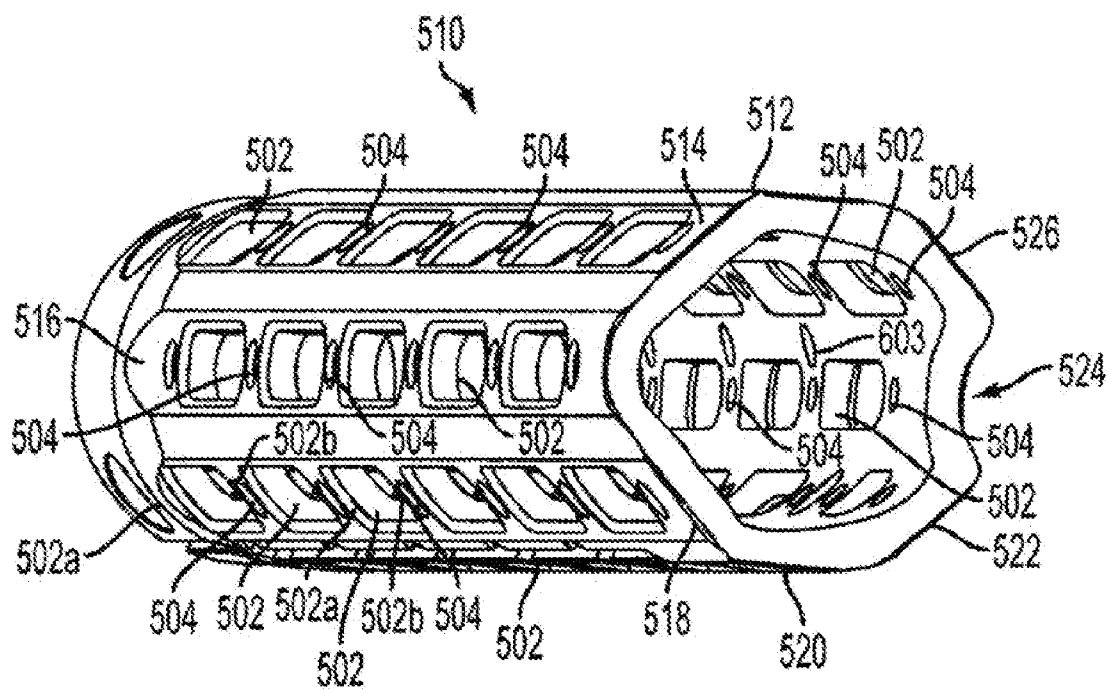

FIG. 14

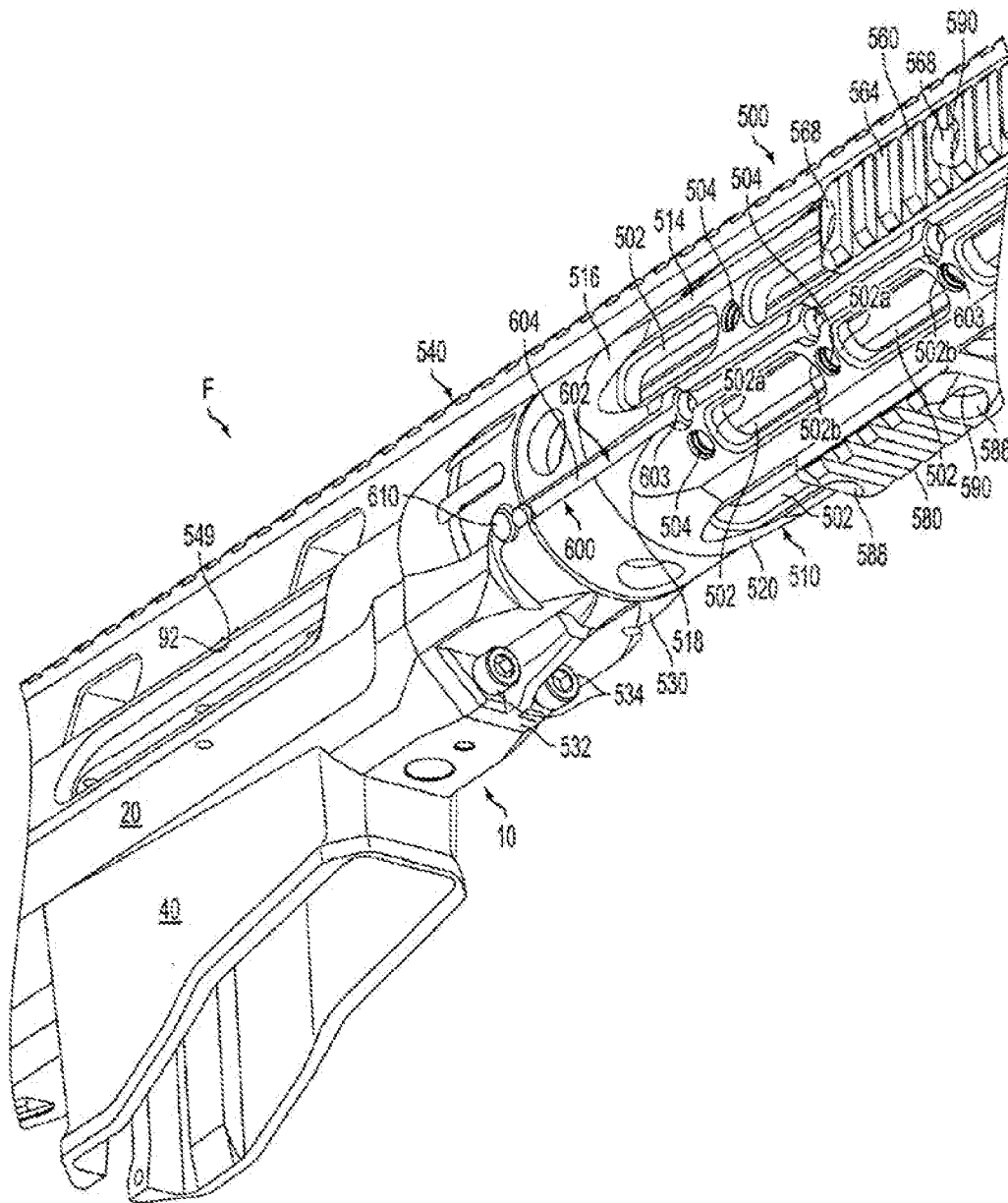

FIG. 15

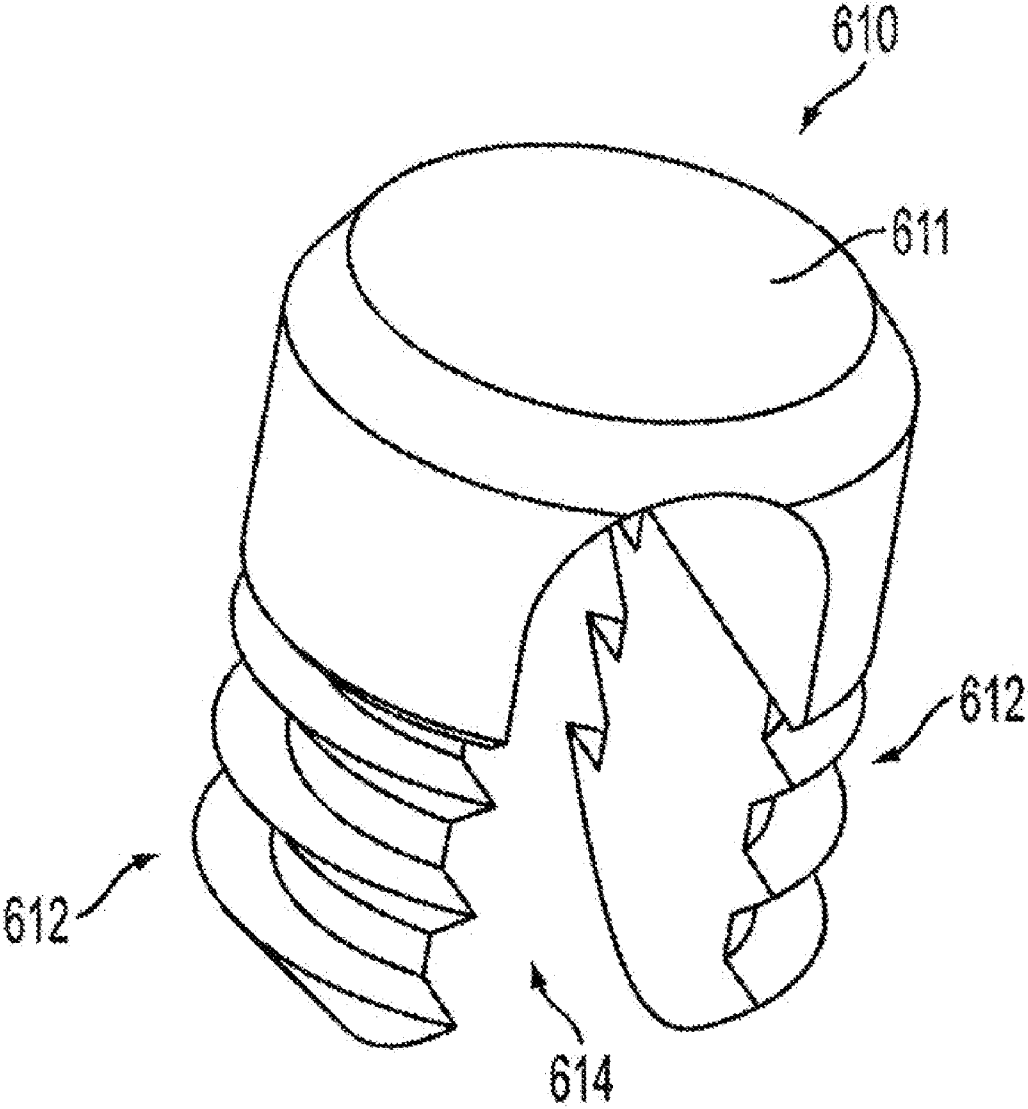

FIG. 16

MODULAR FIREARM STOCK SYSTEM

CONTINUITY

[0001] This application is a continuation of and claims priority to U.S. application Ser. No. 12/640,531, filed on Dec. 17, 2009, which claims priority to U.S. application Ser. No. 61/184,630, filed Jun. 5, 2009. The specifications of which are incorporated herein in their entirety by reference.

FIELD OF THE INVENTION

[0002] The present disclosure relates to a modular firearm.

BACKGROUND OF THE INVENTION

[0003] Typically, most conventional firearms have been adapted for specific tasks and generally are limited to use with specific calibers and/or types of ammunition. However, demand is increasing for firearms that can be modified to fire different types of ammunition, and/or can be reconfigured for different environments and uses. For example, in military applications today, the environments in which soldiers are forced to fight are changing such that they can be in open desert and then move into close quarter's battle in a more urban area within the matter of a few hours. At the same time, their weapons needs can further change, i.e., they might be faced with need for a longer range, sniping weapon or alternatively with needs for a more standard infantry rifle depending on the environment or situation. Carrying multiple different firearms is, however, impractical as adding undue weight and bulk to soldiers' packs and gear. Additionally, for more specialized uses, such as for sniping and other tactical situations, the weapon must be configurable as needed to fit the shooter's particular needs and/or use in a particular combat situation.

SUMMARY

[0004] The present disclosure generally is related to a modular firearm that is easily reconfigurable based on operational needs. More specifically, the disclosure relates to a modular firearm that is configurable to enable operation using ammunition of different or varying calibers via interchangeability of minimal parts, accommodates a variety of different accessories, is easily convertible from an operating condition to a compact and secure transport configuration, and can be configured with various accessories and stock arrangements as needed to meet a specific combat or tactical situation and/or the preferences of the user/shooter.

[0005] According to another embodiment, the modular firearm can comprise a folding butt stock assembly that is moveable between an extended position for placing the firearm in an operating configuration and a folded position for placing the firearm in a transport configuration. The butt stock assembly includes a latch mechanism including a latch arm operable to remove a detent element from engagement with a chassis of the firearm, thereby enabling the stock to be unlocked from the extended position and pivoted into its folded position. In the folded position, the latch arm lockingly engages the chassis of the firearm, thereby securing the butt stock in the folded position. According to a further embodiment, the butt stock assembly can include a bolt handle opening configured to receive and retain a portion of the bolt assembly, such as, a projection, tab, or a bolt handle of the bolt

assembly of the firearm when the butt stock is in the folded position, thereby helping to secure the bolt during transport of the firearm.

[0006] According to a further embodiment, the modular firearm can additionally comprise a modular hand guard assembly for mounting accessories on the firearm. The hand guard assembly includes a hand guard having a plurality of rail mounting platforms, with each platform being disposed in a separate plane, including a top rail for mounting accessories on a top platform of the hand guard, and which attaches the hand guard assembly to a top portion of the receiver, and one or more rail sections attached about different planes of the hand guard and firearm for mounting accessories on the firearm. A bottom portion of the hand guard assembly can also be attached to a chassis of the firearm, with the hand guard assembly generally being free from direct attachment to a barrel of the firearm. One or more recoil-absorbing mounting lugs further may be integrated in each rail or rail section.

[0007] According to still another embodiment, the modular firearm can include an integrated wire management system including one or more wire channels formed in an exterior surface of a chassis of the firearm and/or in an exterior surface of a hand guard of the firearm for accommodating cabling for one or more firearm accessories. Clips may be inserted in the channel(s) to secure the cabling and/or accessories at various locations along the channel(s).

[0008] According to yet another embodiment, the modular firearm further may include an actuator for a bolt stop/guide mechanism. The actuator may be centrally located on an upper rear surface of the receiver to enable ease of actuation or engagement by right and left-handed users.

[0009] Those skilled in the art will appreciate the above features and advantages, as well as additional features and advantages upon reading the following detailed description with reference to the accompanying drawings and appendix.

DESCRIPTION OF THE FIGURES

[0010] The FIG. 1 is a side view showing one embodiment of a modular firearm, according to one example embodiment;

[0011] FIG. 2 is a partial cross-sectional view of the firearm;

[0012] FIG. 3 is a perspective view of a barrel assembly of the firearm;

[0013] FIG. 4 is an exploded view of a bolt assembly of the firearm;

[0014] FIG. 5 shows an interchangeable bolt head of the bolt assembly, according to an embodiment, for use with the modular firearm of the present invention;

[0015] FIG. 6 is a perspective view of the firearm illustrating operation of the bolt assembly of FIG. 5;

[0016] FIGS. 7-8 show an embodiment of a modular ammunition magazine for use with the modular firearm of the present invention;

[0017] FIGS. 9 and 10 show an ammunition magazine conversion block, according to one example embodiment;

[0018] FIGS. 11A-11C are partially transparent views showing a butt stock assembly for the modular firearm, according to one example embodiment, and illustrate a process for folding the butt stock assembly from an extended position for operating the firearm to folded position for transporting the firearm;

[0019] FIG. 12 is a perspective view of the butt stock in a folded position;

[0020] FIG. 13 is a side view showing a modular hand guard assembly and cable management system for use with the modular firearm, according to an embodiment;

[0021] FIG. 14 is a perspective view of a hand guard of the hand guard assembly;

[0022] FIG. 15 is a bottom perspective view showing the connection of the hand guard assembly to a receiver of the modular firearm; and

[0023] FIG. 16 shows a retaining clip of the cable management system.

DESCRIPTION OF THE INVENTION

[0024] FIGS. 1-16 show various features and components of a modular firearm F according to at least one example embodiment of the invention. In particular, the modular firearm F is shown as a bolt-action rifle, and more specifically, a bolt-action sniper rifle. However, it will be understood by those skilled in the art that the various aspects of the invention as described herein are suitable for other types of firearms, including various types of semi-automatic and fully automatic firearms such as handguns, rifles, shotguns, and other long-barreled firearms.

[0025] As shown in FIG. 1, the modular firearm F generally includes a frame or chassis 10 including a receiver 20, an interchangeable barrel assembly 100 mounted to the receiver 20 at a front end 12 of the chassis 10 and defining a chamber 30 at a position where the barrel assembly 100 connects to the receiver 20, a magazine well 40 defined in the chassis 10 and in communication with the chamber 30, and a foldable butt stock assembly 400 mounted to a rear end 14 of the chassis 10. A pistol-style handgrip 50 can be connected to the chassis 10 adjacent the rear end 14 of the chassis 10, and a modular hand guard assembly 500 can be located along the front portion of the chassis 10 to assist in gripping and holding the firearm F. An interchangeable bolt assembly 200 generally is slidably received in the receiver 20 for operation of the firearm F. A fire control 60 is mounted to the chassis 10 for controlling firing of the firearm F. Additionally, ammunition magazine 300 will be received in the magazine well 40 for supplying ammunition to the receiver 20.

[0026] Still referring to FIG. 1, the receiver 20 generally will be constructed of a high strength, durable, but light-weight material, typically a metal or metal alloy such as a titanium alloy. Referring to FIG. 2, a barrel engagement portion 22 of the receiver 20 can be constructed of the same material as the remainder of the receiver 20, or the barrel engagement portion 22 can be constructed of a different, durable, high strength material. For example, the barrel engagement portion 22 can be constructed of steel, thereby providing a steel-on-steel lockup arrangement between the barrel engagement portion of the receiver and the barrel extension 120 (FIGS. 2 and 3) when the barrel extension 120 is also constructed of steel. As shown in FIGS. 1 and 2, the receiver 20 includes a breech 24 through which casings from spent ammunition cartridges may be ejected from the firearm F.

[0027] Referring to FIGS. 1 and 2, the fire control 60 is provided for actuating/firing the firearm F and includes a trigger 62 as part of a trigger assembly housed in the chassis 10. The fire control 60 is operably connected to the firing pin 260 such that actuation of the trigger 62 operates a firing pin 262 (FIG. 2) to fire the firearm F. The fire control 60 can include an adjustable fire control system such as a Remington Arms Company, Inc. X Mark Pro fire control system, which

generally is adjustable to enable variable pressure/trigger pulls, for example, from about 2.4 to about 4.5 pounds of pressure for actuation of the trigger assembly, although more or even less pressure also can be used as understood in the art.

[0028] As shown in FIG. 3, the barrel assembly 100 includes a barrel 110 and a barrel extension 120 for mounting the barrel 110 to the receiver 20. The barrel 110 and barrel extension 120 define a central axial bore 102 and can be integrally formed so as to define a substantially unitary, single piece barrel assembly, or can be separately formed and adapted to connect together as a multi-piece barrel assembly. The forward or distal end 122 of the barrel extension 120 can be attached to a rear end 114 of the barrel by a threaded connection or adhesive bond, for example. A rear end 124 of the barrel extension 120 can be attached to the barrel engagement portion 22 of the receiver 20 at the front end 12 of the chassis 10 in a known manner. A locking aperture 126 for interfacing with the bolt assembly 200 is formed at the rear end 124 of the barrel extension 120 in alignment with the central axial bore 102. The locking aperture 126 includes a central aperture or bore 127 that communicates with the bore 102 of the barrel, and a plurality of recess portions 128 projecting radially outwardly from and spaced about the central aperture or bore 127 of the barrel.

[0029] Referring to FIGS. 2, 4 and 5, the bolt assembly 200 of the firearm F generally includes a substantially hollow bolt body 210, an interchangeable bolt head 230 that can be configured to fit ammunition cartridges of a specific caliber, a bolt plug 250, and a firing pin assembly 160. The bolt body 210 typically includes a bolt handle 214 that can be grasped for sliding the bolt body 210 within the receiver 20, an axial bore 216 longitudinally extending from a rear or distal end 212 to a front or proximal end 211, and a transverse locking bore 213 located adjacent the front end 212 of the bolt body as indicated in FIG. 4. The bolt body 210 further generally includes a bolt guide channel 217 formed in an exterior surface of the bolt body 210. The bolt guide channel 217 includes a transversely extending channel segment 218 located near the rear end 212 of the bolt body 210, and an axially extending channel segment 219 extending from the transversely extending segment 218 towards the front end 211 of the bolt body 210. The bolt guide channel is adapted to be engaged by a guide member or rail within the receiver for guiding the bolt assembly during a loading and cocking operation of the firearm.

[0030] As illustrated in FIGS. 4 and 5, the bolt head 230 includes a front or proximal end 231 configured to engage an ammunition cartridge as shown in FIG. 2, a rear or distal end 232 configured to be received in and attached to the bolt body 210, and radially projecting locking lugs 234 (FIG. 5) located along the side wall of the bolt body adjacent the front end 231. The locking lugs 234 are configured to selectively engage the locking aperture 126 (FIG. 2) of the barrel extension 120 for securing the bolt head 230 in place during firing of the firearm F, as will be described later. As shown in FIGS. 4-5, the bolt head 230 further includes an axially extending firing pin bore 235 that aligns with the tip portion 268 of the firing pin 262 of the firearm, a transverse bolt head locking bore 236, an axially extending extractor mounting channel 237, aligned transverse pivot pin bores 238 intersecting the extractor mounting channel 237, an axially extending ejector mounting bore 239, and a transverse ejector locking channel 240.

[0031] Referring again to FIG. 4, the bolt head 230 is releasably mountable to the front end 211 of the bolt body 210 by engagement of a locking pin 247 that is insertable in the

transverse bolt head locking bores **213**, **236** to enable removal and/or change-out of the bolt face as needed to change the caliber of the firearm and enable firing of different types/calibers of ammunition. The locking pin **247** further can be configured so as to include an axial bore **248** for receiving a tip portion **268** of a firing pin **262** therethrough so as to enable the bolt face change-out without interfering with or requiring change-out of the firing pin as well.

[0032] Referring to FIG. 5, one or more extractors **241** can be pivotally mounted in one or more extractor mounting channels **237** (only one shown) by engagement with a pivot pin **243** inserted through the transverse pivot pin bores **238**. A biasing spring **242** can be inserted in the extractor mounting channel **237** between the bolt head **230** and the extractor **241** to pivotally bias the extractor **241** toward an engaging position for engaging and holding the ammunition cartridge for extraction upon operation of the bolt assembly after firing. As further indicated in FIG. 5, an ejector **244** can be mounted in the ejector mounting bore **239** with a locking pin **245** inserted through an ejector locking channel **240** for releasably securing the ejector. An ejector spring **246** generally coaxially positioned with the ejector **244** along the ejector mounting bore **239**, so as to bias the ejector forwardly and control axial movement during extraction and ejection of the spent cartridge by the ejector **244** of the bolt head.

[0033] As illustrated in FIG. 4, the bolt plug **250** is generally hollow so as to define an axial bore **256** therethrough, and includes a front portion **252** insertable in the rear end **212** of the bolt body **210**, a rear portion **254**, and an axial bore **256** extending from the front portion **252** to the rear portion **254** for receiving the firing pin assembly **260**. The rear portion **254** of the bolt plug **250** is configured to abut the rear end **212** of the bolt body **210** and thereby limit the depth of insertion of the front portion **252** in the bolt body **210**.

[0034] Still referring to FIG. 4, the firing pin assembly **260** includes the firing pin **262**, which includes a head portion **264** mountable within the axial bore **256** of the bolt plug **250**, a body portion **266** insertable in the axial bore and mountable to the head portion **264**, and a tip portion **268**, which projects forwardly from the body portion **264** so as to extend through the bore **235** of the bolt head assembly for engaging and firing a round of ammunition or cartridge within the chamber of the firearm. The firing pin assembly **260** further generally includes a recoil spring **269** mountable around the body portion **266**.

[0035] When the bolt assembly **200** is assembled as shown in FIG. 2, the bolt head **230** is connected to the front end **211** of the bolt body **210**, the firing pin assembly **260** is connected to the bolt plug **250**, and the bolt plug **250** and firing pin assembly **260** are inserted into the bolt body **210**. Specifically, the rear end **212** of the bolt head **210** is inserted into the axial hole **216** in the bolt body **210** through the front end **211** of the bolt body **102**, and the transverse locking bore **236** in the bolt head **230** is aligned with the transverse locking bores **213** in the bolt body **210**, and the locking pin **247** is inserted through the locking bores **213**, **236**, thereby securing the bolt head **230** to the bolt body **210**. The firing pin assembly **260** is mounted to the bolt plug **250** such that the firing pin **262** is inserted through the axial bore **256** of the bolt plug **250**, the head portion **264** of the firing pin is attached to the bolt plug **250**, the body and tip portions **266**, **268** of the firing pin extend from the front portion **252** of the bolt plug **250**, and the recoil spring **269** is positioned around the body portion **266** of the firing pin. The body and tip portions **266**, **268** of the firing pin

262 and the front portion **252** of the bolt plug **250** are inserted into the bolt body **210** such that the tip portion **268** of the firing pin **262** is aligned with and can be actuated to extend through the axial firing pin bore **235** and the axial bore **248** in the locking pin **247**. The rear portion **254** of the bolt plug **250** further typically is secured to the rear end **212** of the bolt body **210** to complete the bolt assembly **200**.

[0036] According to one example embodiment, the length of the bolt assembly **200** can allow feeding and ejection of various length ammunition cartridges up to 4.2" long, although various other larger or smaller size and/or caliber cartridges also can be used. If it is desired to change the caliber of ammunition used with the firearm F, the bolt assembly **200** can easily be removed from the firearm F, and the bolt head **230** can be disconnected from the bolt assembly **200** by removing the locking pin **247** from the transverse locking bores **213** and **236**. With the locking pin removed, the bolt head **230** can be disengaged from the bolt body **102**. The bolt head **230** can then be replaced in the bolt assembly **200** with a replacement bolt head of the desired ammunition caliber, and the bolt assembly including the replacement bolt head can be reinstalled in the firearm F. Additionally, the barrel **110** (FIG. 3), which defines a chamber of a first ammunition caliber, also generally will be disengaged from the receiver of the firearm and a new, second barrel defining a chamber configured to receive ammunition cartridges of a second, different caliber or size can be installed in its place to facilitate firing of a new, different caliber or type of ammunition. Together with various size ammunition magazines, or a reconfigurable magazine as noted below, the interchangeable barrel and bolt assembly can define a simple and different caliber conversion system or assembly for the firearm.

[0037] As shown in FIGS. 2 and 6, when the firearm F is in a normal operational condition for firing a round of ammunition, the bolt assembly **200** is slidably mounted in the receiver **20** for chambering and ejecting ammunition. A bolt stop lever **80** is pivotally mounted to the receiver **20**. The bolt stop lever **80** is located at a central, upper, rear region of the receiver **20**, and includes an external grip portion **82** and a guide arm **84** extending from the grip portion **82**. The grip portion **82** is exposed on the external surface of the firearm F at the central, upper, rear region of the receiver **20**, and is operable by a user's finger or thumb at the exterior of the firearm F to pivot the bolt stop lever **80** in directions U1, U2. The guide arm **84** selectively registers with the guide channel **217** (FIG. 4) extending along the bolt body **210** based on the pivotal position of the bolt stop lever **80**. The bolt stop lever **80** may be biased in the direction U2 by a biasing member, such as a spring **86**, to protect against accidental disengagement of the bolt stop lever with the guide channel **217**. As FIG. 2 indicates, the bolt stop lever cooperates with a transverse channel segment **218** of the channel **217** (FIG. 4) in the bolt body **210** to guide forward and rearward linear movement of the bolt assembly **200** in the directions L1, L2, guide rotation of the bolt assembly **200** about its central axis in the directions T1, T2 and selectively stop or limit travel of the bolt assembly **200** in the rearward direction L2. Thus, the channel **217** and the lever **80** together form a bolt stop and guide mechanism. As FIG. 2 indicates, the engagement of the lugs **234** with locking aperture **126** helps to limit rearward linear movement of the bolt assembly **200** in the direction L2, so as to assist in selectively stopping or limiting travel of the bolt assembly **200** in the rearward direction L2.

[0038] In operation of the bolt assembly **200** and the bolt stop lever, as shown in FIGS. **2** and **6**, the bolt assembly **200** generally is disposed in a forwardmost, position in the receiver and rotated in the direction **T1** about its central axis with the bolt handle **104** turned to and its downwardmost position, when in an operating condition. The bolt head **230** extends through the locking aperture **126** in the barrel extension **120** and is oriented such that the locking lugs **234** are out of alignment with the outer aperture portions **129** of the locking aperture **126**, thereby locking the bolt head **230** in the barrel extension **120**. The bolt stop lever **80** is in its downwardmost position in the direction **U1** such that the guide arm **84** is in registry with the transverse channel segment **218** of the channel **217** in the bolt body **210**. With the bolt assembly **200** and the bolt stop lever **80** in this configuration, the bolt assembly **200** is restricted from moving in the directions **L1**, **L2** and the firearm **F** is configured for firing a round of ammunition **C1** from the chamber **30**.

[0039] In order to eject a round of ammunition **C1** (FIG. **2**) or a casing of a spent round of ammunition **C1** from the magazine well **40** into the receiver **20**, the bolt assembly **200** can be rotated in the upward in the direction **U2** and moved rearward in the direction **L2**. Specifically, the bolt assembly **200** can be rotated in the upward in the direction **U2** such that the guide arm **84** is in registry with the axial channel segment **219** and the bolt handle **214** is in its upwardmost position. With the bolt assembly **200** in this position, the locking lugs **234** of the bolt head **230** are aligned with the outer aperture portions **129** of the locking aperture **126**. After rotating the bolt assembly **200** in the direction **U2** as described, the bolt assembly **200** can be moved rearwardly in the direction **L2** to its rearwardmost position such that the bolt head **230** passes out of the locking aperture **126**.

[0040] During rearward movement of the bolt assembly **200**, the extractor **241** (FIG. **5**) will grab the casing/ammunition round **C1** and the ejector **244** will eject the casing/ammunition round **C1** from the breech **24** (FIG. **2**). The bolt assembly **200** is restricted from rotating during its rearward movement. When the bolt assembly **200** is in its rearwardmost position, the guide arm **84** remains in registry with the channel segment **219**, engaging a front edge of the channel segment **219** to prevent the bolt assembly **200** from being inadvertently removed from the receiver **200**. If it is desired to remove the bolt assembly **300** from the receiver (to replace the bolt head **110**, for example), the bolt stop **80** may be pivoted downward in the direction **U1** to deregister the guide arm **84** and disengage the locking lugs from the locking aperture, thereby allowing the bolt assembly **200** to slide rearwardly out of the receiver **20**.

[0041] As indicated in FIGS. **2** and **6**, after ejecting a spent cartridge or round, the bolt assembly **200** may be moved forward in the direction **L1** from its rearwardmost position in order to advance a next or new ammunition cartridge **C1** from the ammunition magazine **300** to the chamber. During such forward movement, the guide channel segment **119** engages the guide arm **84** such that the bolt assembly **200** cannot rotate in the directions **T1**, **T2** until the bolt assembly reaches its forwardmost position in the receiver. The bolt assembly **200** then can be turned downwardly in the direction **T1** to lock the bolt assembly **200** in position for firing the round of ammunition **C1**, as described above.

[0042] As perhaps best shown in FIG. **6**, the location of the bolt stop lever **80** enables ambidextrous operation of the bolt stop lever **80**. Additionally, with the bolt stop lever **80** posi-

tioned centrally on an upper rear surface of the receiver **20**, the bolt stop lever **80** is naturally shielded by a top rail **540** (described in detail later) and potentially by a scope or other aiming optics (not shown) or accessories that may be mounted on the top rail **540**. Inadvertent operation of the bolt stop/guide lever **80** can therefore be prevented without the requirement of additional fencing material or a cover.

[0043] Referring to FIGS. **2**, **7** and **8**, a magazine **300** generally will be received within the magazine well **40**. In one embodiment, the magazine **300** can be a modular, interchangeable magazine including a magazine box or magazine body **302**, as shown in FIGS. **7-8** and having a removable bottom plate **307**, and a magazine follower assembly **310** disposed in the magazine body **302** for advancing ammunition cartridges towards the top of the magazine body **302**. As indicated in FIG. **7**, the bottom plate **307** of such a magazine can be removed from the magazine body **302** to enable repair or replacement/reconfiguration of parts by sliding the bottom plate forward in the direction **L1** off of the magazine body **302**. Conversely, the bottom plate **307** can be reconnected to the magazine body **302** by sliding the bottom plate rearwardly in the direction **L2** onto the magazine body **302**.

[0044] As an example, the magazine **300** can be a center feed, double stack type magazine capable of feeding ammunition from 1-2 stacked, parallel rows or groups as indicated in FIGS. **2** and **7-8**. A spring-loaded magazine release button **304** (FIGS. **6** and **9**) can be provided on a rear wall **303** of the magazine body **302** for selectively locking the magazine **300** in the magazine well **40** and releasing the magazine **300** from the magazine well **40**. Specifically, when the magazine **300** is inserted in the magazine well **40**, the spring-loaded release button **304** is biased into engagement with a locking aperture **42**, which is positioned in a rear wall of the magazine well **40**, adjacent the receiver **20** and above a trigger guard **66** of the firearm **F**. The spring-loaded release button **304** can be depressed to disengage the locking aperture **42** and allow the magazine **300** to be removed from the magazine well **40**.

[0045] In another embodiment, the magazine **300** can be adjustable so as to be reconfigurable to accommodate cartridges of different lengths, sizes, and/or different calibers of ammunition within a specific caliber by way of a removable/interchangeable spacer **320** that is insertable in the magazine body **302** at a front end **305** thereof. As illustrated in FIGS. **7** and **8**, the magazine **300** generally can be configured to accommodate standard length ammunition cartridges **C1** when the spacer **320** is installed in the magazine body **302**. A cutout or channel **322** (FIG. **8**) is provided in the spacer **320** and is configured to receive and retain front ends of the cartridges **C1**. The spacer **320** is configured to extend substantially from a top **306** to the bottom plate **307** of the magazine body **302**. As perhaps best shown in FIG. **7**, the spacer **320** can include resilient detent members **324** configured to lock the spacer **310** within the magazine body **302** by engaging locking channels **309** in side walls **308** of the magazine body **302**. The spacer **320** can be connected to the magazine body **302** by removing the bottom plate **307** and inserting the spacer upwardly into the magazine body in the direction **H1** until the detent members **324** lockingly engage the locking channels **309**.

[0046] As indicated in FIGS. **2** and **8**, the magazine **300** can be configured to accommodate longer, non-standard length ammunition cartridges **C2** when the spacer **320** is removed from the magazine body **302**. As FIG. **8** illustrates, the spacer **320** can be removed from the magazine body **302** by depress-

ing the detent members 324 until the detent members 324 disengage the locking channels 307, and then moving the spacer 320 downward in the direction H2, out of the magazine body 302.

[0047] It is further envisioned that the spacer 320 can be interchanged with other spacers of different configurations to accommodate other ammunition cartridges of various lengths/sizes and/or calibers. Additionally, the magazine 300 may be interchanged with other magazines configured to accommodate ammunition cartridges of different calibers and/or lengths. For example, as shown in FIGS. 9-10, the receiver 20 can include a conversion block mounting bore 44 adjacent the magazine well 40 for mounting a magazine conversion block 350 in the magazine well 40. The magazine conversion block 350 can be, for example, a 7.62 mm NATO conversion block that enables smaller 7.62 mm NATO ammunition magazines to be inserted in the magazine well 40. Referencing FIG. 10, the magazine conversion block 350 includes a cradle portion 351 for receiving an ammunition magazine (not shown) that is smaller than the magazine 300 described above. As illustrated in FIGS. 9 and 10, the magazine conversion block 350 includes catch assembly 354 including a release arm 356 that is biased rearward in the direction L2 by a pivotable biasing arm 358. The biasing arm 358 is biased rearward against the release arm 356 by a torsional spring 359. The magazine conversion block 350 also has a central mounting bore 360 configured for alignment with the conversion block mounting bore 44.

[0048] As can be understood from FIGS. 9 and 10, the magazine conversion block 350 can be installed in the magazine well 40 by sliding the conversion block 350 upward in the direction H1 until the release arm of the magazine release button 304 (FIG. 9) snaps into the locking aperture 42 above the trigger guard 66 and the central mounting bore 360 is aligned with the conversion block mounting bore 44. A fastener 362, such as a bolt or screw, can then be inserted into the bores 360, 44 to secure the magazine conversion block 350 in place. The magazine conversion block 350 can be uninstalled from the magazine well 40 by removing the fastener 362, pressing the release arm 356 forward in the direction L1 against the bias of the biasing arm 358 until the release arm 356 disengages the locking aperture 42, and then sliding the magazine conversion block 350 downward in the direction H2 out of the magazine well 40.

[0049] It can be understood from the above disclosure that, due to the reconfigurability of the barrel assembly 100 and the bolt assembly 200, the firearm F can be modified to operate with ammunition of multiple calibers by changing or reconfiguring only the barrel 100, bolt head 230, and the magazine 300 if needed. According to one example, the barrel assembly 100, bolt head 230 and magazine 300 may be packaged together as a caliber conversion assembly or kit configured for operation with ammunition of a specific caliber. Due to the modular designs of the barrel assembly 100, the bolt assembly 200 and the magazine 300, the barrel assembly 100, bolt head 230 and magazine 300 can easily and quickly be installed in and uninstalled from the firearm F to replace and be replaced by respective barrel assemblies, bolt heads and magazines as needed for accommodating operation of the firearm with ammunition of other, different calibers and/or sizes. For example, the firearm F can be convertible to operate with ammunition calibers including, but not limited to, 338 Lapua Magnum and 300 Winchester Magnum. Furthermore, with the use of the magazine conversion block 350, operation

of the firearm F with 7.62 mm NATO ammunition is possible. It should be understood that, due to the modular design of the barrel assembly 100, bolt assembly 200, the firearm F also can be configured to be convertible to operate with ammunition calibers other than those specifically discussed.

[0050] FIGS. 1 and 11A show the firearm F in a shooting configuration with the foldable butt stock assembly 400 in an extended position, in line with the chassis 10. As illustrated in FIGS. 1 and 11A-11C, the butt stock assembly 400 includes a butt stock 410 having a body or frame 405, and a hinge member 430 connected to a front end 411 of the butt stock 410. The hinge member 430 is pivotally connected to hinge bracket 28 at the rear or distal end 14 of the chassis by a hinge pin 432. A threaded member such as a screw 434 can extend transversely to and bear against the hinge pin or bolt 432 within the hinge member 430 to reduce slack or spacing in the connection between the hinge member 430 and the hinge bracket 28, and further helps prevent the hinge pin 432 from separating from the chassis system. The axial position of the screw 434 in the directions L1, L2 can be adjusted to vary the degree to which the screw 434 bears against the hinge pin 432, and thereby adjust the amount of slack in the connection between the hinge member 430 and the hinge bracket 28. The butt stock 410 includes a bolt handle window or opening 412 for receiving the bolt handle 214 when the stock is in the folded (or retracted) configuration (FIGS. 11C-12).

[0051] An adjustable butt plate 414 further generally is connected to a rear end of the stock body or frame 405. The butt plate 414 can be vertically adjustable upwardly and downwardly in the directions H1 and H2 by an adjustment feature or member 422 adjacent a lower or bottom portion of the butt plate and pad 414. The length of pull of the butt plate is adjustable, as indicated by arrows L1-L2 in FIG. 1, by engagement/rotation of a first adjustment knob or wheel 416. An adjustable cheek piece or comb 418, typically formed from a resilient cushioning material, also can be connected to the stock body 405, extending upwardly from the butt stock 410, and is adjustable in a vertical direction with respect to the firearm F via a second adjustment knob or wheel 420. As a result, the comb or cheek piece 418 can be adjusted in the direction of arrows H1-H2 to fit a user's preference or comfort. The cheek piece further can be adjusted in the longitudinal direction (indicated by arrows L1-L2) by disengaging fasteners securing the cheek piece, adjusting it forwardly or rearwardly as desired, and thereafter resecuring the cheek piece with the fasteners. Additionally the length of pull of the butt stock assembly 400 can be adjustable via the addition and removal of spacers, that are insertable between the butt stock body 405 and the butt plate 414. According to an exemplary embodiment, the length of pull may be adjustable between about 12.4 inches and about 14.4 inches.

[0052] FIGS. 11A-11C illustrate a latch mechanism 440 for the foldable butt stock assembly 400, which is operable to selectively enable pivoting of the butt stock assembly 400 between an extended configuration (FIGS. 1 and 11A) and a folded configuration (FIGS. 11C and 12). In the extended position, the butt stock assembly 400 extends rearwardly from the rear end 14 of the chassis 10, in line with the chassis 10 (FIGS. 1 and 11A), enabling the firearm to be operated. In the folded configuration, the butt stock assembly 400 extends forwardly from the rear end 14 of the chassis 10, substantially parallel to the chassis 10, and is secured to a lateral side of the chassis 10, thereby reducing the length of the firearm F to facilitate transporting the firearm.

[0053] As shown in FIGS. 11A-11B, the latch mechanism 440 generally includes a substantially L-shaped, pivotable latch arm 442 having a first arm portion 444 extending transversely to the longitudinal axis X of the firearm F/butt stock assembly 400, a second arm portion 446 extending from the first arm portion 444 in a direction substantially perpendicular thereto along the axis X, and a pivot pin 448 provided at a junction of the first and second arm portions 444, 446. A detent element or boss 450 is connected to a free end of the second arm portion 446 and extends substantially perpendicular thereto. The first arm portion 444 is partially housed within the hinge member 430 and has a free end protruding from a side of the hinge member 430 and terminating at a tab 445. The second arm portion 446 extends within the hinge member 430. The boss 450 is disposed within a transverse bore 452 in the hinge member 430 and is selectively received within a locking opening pocket 453 mounted to the hinge member 430 and positioned laterally opposite the hinge pin 432. A biasing spring 454 located within the bore 452 biases the boss 450 in the lateral direction indicated by the arrow Z1. When the butt stock assembly 400 is in the extended position shown in FIGS. 1 and 11A, the locking pocket 46 is aligned with the transverse bore 452 and the boss 450 is retained in a locking opening or pocket 453 under the biasing force of the spring 454. Thus, the boss 450 locks the butt stock assembly 400 and the chassis 10 together such that the butt stock assembly 400 cannot be pivoted with respect to the chassis 10.

[0054] FIGS. 11B-12 illustrate a process for pivoting the butt stock assembly 400 from the extended configuration of FIGS. 1 and 11A to the folded configuration of FIGS. 11C-12. As shown in FIG. 11A, the butt stock assembly 400 can be unlocked from the chassis 10 by moving the tab 445 in the rearward direction of the firearm as indicated by the arrow L2 which causes the latch arm 442 to pivot clockwise about the pivot pin 448, in the direction indicated by the arrow P1. As a result, the boss 450 is moved against the biasing force of the spring 454 in the lateral direction indicated by the arrow Z2, and is removed from the locking pocket 453, thereby unlocking the butt stock assembly 400 from the chassis 10. Thereafter, as shown in FIGS. 11B-11C, the butt stock assembly 400 can be pivoted counterclockwise about the hinge pin 432, in the direction indicated by the arrow P2 at the hinge 432. Once the butt stock 200 is pivoted in the direction P2 to a point at which the boss 450 is out of alignment with the locking pocket 453, the tab 445 may be released, causing the boss to be moved in the direction Z1 under the biasing force of the spring 454, and thereby causing the lever arm 442 to be pivoted counterclockwise in the direction P2 under the biasing force of the spring 454. The butt stock 400 then may be pivoted until the butt stock is positioned adjacent the chassis 10 and extends substantially parallel thereto (FIG. 12).

[0055] When the butt stock assembly 400 is positioned in this folded configuration or manner, the tab 445 lockingly engages a locking feature located on the sidewall of the chassis 10 adjacent the butt stock assembly 400, shown in FIG. 11C as including, for example, a locking plate 70, thereby securing the butt stock assembly 400 in the folded position. Specifically, the tab 445 lockingly engages an edge 73 of an opening 72 in the locking plate 70 or other, similar locking feature as will be understood by those skilled in the art. As shown in FIGS. 11C and 12, when the butt stock assembly 400 is secured in the folded position, the bolt handle 214 extends through and is retained within the bolt handle opening 412, thereby preventing movement and operation of the

bolt assembly 200. Additionally, when the butt stock assembly 400 is in its folded position, the boss 450 protrudes from the firearm F through the transverse bore 452, as indicated in FIG. 12. The tab 445 can be released from locking engagement with the edge 73 of the locking plate 70 by pressing the boss 450 against the biasing force of the spring 454 in the direction indicated by the arrow Z2, which causes the latch arm 442 to pivot clockwise in the as indicated by the arrow P1. Thereafter, the butt stock assembly 400 can be pivoted clockwise about the hinge pin 432 in the direction P1 and the boss 450 can be released and allowed to move in the direction Z1 under the biasing force of the spring 454. The butt stock assembly 400 can then be pivoted in the direction P1 until the butt stock assembly 400 is secured in its extended position, as described above with respect to FIGS. 1 and 11A.

[0056] As indicated in FIGS. 11A-11B, the locking opening or pocket 453 retains the boss 450 until the force of the spring 454 is overcome by rotation of the butt stock assembly, and generally is aligned with the boss 450 when the stock is in its extended position. The position and/or alignment of the pocket 453 further can be adjusted as needed to accommodate changes in the butt stock assembly. As indicated in FIGS. 11A-11C, a locking set screw or similar locking member 460 can be located just above the locking opening or pocket 453 to secure the position thereof with respect to the boss 450 when the butt stock assembly is in its extended position. When this set screw is loosened, 453 can be rotated and thereby taking the "slop" or variance out of the union between the lower stock assembly and the buttstock assembly. The receiving bore of the locking pocket 453 also is generally eccentrically shaped, and rotating the pocket, which thus rotates the receiving bore with respect to the boss 450, tightens up the interaction between the receiving bore of the locking pocket 453 and the boss 450 to help ensure secure and constant engagement of the boss 450 within the receiving bore of the locking pocket 453 to lock the stock in its extended position. Once the desired adjustment of the locking pocket is made, the set screw 460 can be tightened to secure or fix the locking pocket 453 in place.

[0057] FIGS. 1 and 13-15 show features of the hand guard assembly 500. As shown in FIGS. 13 and 14, the hand guard assembly 500 includes a substantially tubular hand guard 510 defining a plurality of rail mounting platforms and a substantially tubular hand guard connector 530 for connecting the hand guard 510 to the front end 12 of the chassis 10. According to the exemplary embodiment illustrated herein, the hand guard 510 defines eight rail mounting platforms including a top platform 512, side platforms 514, 516, 518, a bottom platform 520, and side platforms 522, 524, 526, with each platform being disposed in a separate plane. Accordingly, the hand guard 510 has an octagonal cross-sectional shape in a plane transverse to the longitudinal axis of the hand guard assembly 500. Each platform 512, 514, 516, 518, 520, 522, 524, 526 includes a plurality of longitudinally spaced vent holes or openings 502 for venting heat from the barrel 110, and a plurality of longitudinally spaced mounting holes 504 for connecting accessory mounting rails 560, 580 to the hand guard 510. In the embodiment shown, the vent holes 502 are substantially oval in shape, and are positioned along the length of the hand guard 510 in alternating arrangement with the mounting holes 504. However, one skilled in the art will understand that other configurations of vent holes and mounting holes are possible.

[0058] As shown in FIGS. 13 and 15, the hand guard connector 530 can be formed integrally with or connected to a rear end of the platforms 512, 314, 516, 518, 520, 522, 524, 526, and includes a flange 532 for connecting the hand guard 510 to the chassis 10. The flange 532 is formed at a lower portion of the hand guard connector 530, and the hand guard connector 532 can be connected to a lower portion of the front end 12 of the chassis 10 with fasteners, such as bolts or screws 534, inserted through the flange 532.

[0059] As also shown in FIGS. 13 and 15, a top accessory mounting rail 540 for mounting accessories to the firearm F is provided on the top platform 512 (at the 12 o'clock position) of the hand guard 510. The top rail 540 can be adjustable and can be a replaceable Mil. Std. 1913 rail, for example. Referring to FIG. 22, the top rail 540 includes a top surface 544 for interfacing with an accessory (not shown) such as a scope or other optic device, a bottom surface 546 for interfacing with the top platform 512. A plurality of mounting holes 548 extend through the top and bottom surfaces 544, 546 for mounting the top rail 540 to the top platform 512. At least one recoil absorbing lug 549 extends from the bottom surface 546 of the top rail 540 at a rear section thereof. Each recoil absorbing lug 549 can be integrally formed with the bottom surface of the top rail 540 or with an associated platform of the hand guard assembly, or can be separately insertable into or engageable with the top rail and/or an associated platform. As shown in FIG. 19, the top rail 540 can be secured to the hand guard 510 by aligning mounting holes 548 with corresponding mounting holes 504 in the top platform 512 and corresponding mounting bores 90 (shown in FIG. 2) in the receiver 20, aligning each and inserting fasteners such as threaded fasteners 550 through aligned mounting holes 548, 504 and aligned mounting holes and bores 548, 90. The recoil absorbing lug can engage a recess in the top of the receiver 20, for seating the lug and helping secure the accessory mounting rail to the receiver. The rail 540 further can be a substantially continuous long rail so as to ensure that all optics and/or accessories mounted on the top rail are planarly aligned.

[0060] Each of the remaining platforms 512, 514, 516, 518, 520, 522, 524, 526 may have one or more accessory mounting rails, such as accessory mounting rails 360, 380, connected thereto for mounting accessories on the firearm F. The rails 360, 380 and any other mounting rails connected to the platforms 512, 314, 516, 518, 520, 522, 524, 526 can also be Mil. Std. 1913 rail sections. The rails 360, 380 may be constructed to be shorter in length than the platforms as shown, or they may be constructed to extend substantially the entire length of the platforms 512, 514, 516, 518, 520, 522, 524, 526.

[0061] Referring to FIGS. 14 and 15, the rails 560, 580 each include a top surface 564, 584 for interfacing with an accessory, a bottom surface 566, 580 for interfacing with one of the platforms 514, 516, 518, 520, 522, 524, 526, a plurality of mounting holes 568, 588, and one or more recoil absorbing lugs 590 received within the Mounting holes 588 formed in the rail surfaces. The Mounting holes 568, 588 are configured to be aligned with corresponding mounting holes 504 in one of the platforms 514, 516, 518, 520, 522, 524, 526. The recoil absorbing lugs 569, 589 also can be formed integrally with the bottom surfaces 566, 586 or the rails or can be inserted into the rail and platform(s) of the hand guard assembly. The recoil absorbing lugs 569 of the rail 560 are spaced such that they are configured to engage a rear edge 502a and a front edge 502b of the same vent hole 502. The recoil absorbing lugs 569 of the rail 560 are spaced such that they are config-

ured to engage a rear edge 502a of one vent hole 502 and a front edge 502b of another vent hole 502.

[0062] Thus, a rail section 360 or 380 can be secured to the hand guard 510 by inserting the pair of lugs 569 or 589 in one or more vent holes, and/or by aligning each mounting hole 568 or 588 with a corresponding mounting hole 504, and inserting fasteners such as threaded fasteners 570 through aligned mounting holes 568 and 504 or aligned mounting holes 588 and 504.

[0063] By way of example, a scope (not shown) or other optic can be attached to the top rail 540 and/or a bipod (not shown) can be attached to a bottom rail section 350. However, because each platform 514, 516, 518, 520, 522, 524, 526 is positioned in its own plane and includes a plurality of mounting holes 502, rails of different sizes and/or configurations can be mounted at various positions and in various configurations and numbers along the length of each platform, thereby enabling various types and combinations of accessories to be mounted on the hand guard 510. Furthermore, it should be understood that the accessory mounting rails 560, 580 can be mounted on other surfaces of the firearm F, such as, but not limited to the butt stock 410 (FIG. 1).

[0064] Due to the manner in which the hand guard assembly 500 is connected to the chassis 10/receiver 20, the hand guard assembly 500 surrounds the barrel 110, but is not directly connected to the barrel 110. Because the hand guard assembly 500 is not directly connected to the barrel 110, the hand guard 510 is substantially free-floating with respect to the barrel, thereby improving accuracy in operating the firearm F. The recoil absorbing lugs 549, 569, 589 absorb recoil forces generated by firing the firearm F and thereby resist shearing of accessories mounted on respective rails 540, 560, 580.

[0065] In addition, radially located sling swivel cups, such as indicated at 700 in FIG. 13, can be attached adjacent the fore-end and the butt stock of the firearm F. There typically can be four sling swivel cups, although more or fewer sling swivel cups also can be used. One to three of these sling swivel cups can be used to attach carrying slings to the weapon via a push-fit sling swivel. The chassis 10 and the buttstock body 400 also can include one or more of such sling swivel cups for attaching an opposite end of the carrying sling thereto.

[0066] Certain electronic accessories, such as optics, which can be attached to the firearm F by mounting on the hand guard 510 or other parts of the firearm F, often require wire or cable connections in or on the firearm. Thus, as illustrated in FIGS. 13 and 15, the firearm F can include a wire management system 600 including one or more wire channels 602 integrated in exterior walls of the chassis 10, the hand guard 510, and/or the hand guard connector 530. One or more wires or cables 604 can be placed in the channel(s) 600 and routed to components and/or accessories in and/or on the firearm F. The wire(s) 604 can be secured in the channel(s) 600 by retaining clips 610 inserted into openings 601 the channel(s) 600. Each retaining clip 610 (FIG. 16) can include a top 611 and a pair of deformable ribbed arms 612 defining a passage 614 therebetween sized to receive a wire 604. The ribbed arms 612 can be configured to engage an opening 601 by a press-in fit. To secure a wire 604 (FIG. 13) in a channel 602, the wire 604 can be inserted through the passage 614 of one or more clips 610, and the each clip 610 can be pressed into an opening 601 in the channel 602. When a clip 610 is pressed

into an opening **601**, the ribbed arms are deformed towards each other and, as a result, engage the wire **604** by an interference fit.

[**0067**] The foregoing disclosure provides illustrative embodiments of the invention and is not intended to be limiting. It should be understood that modifications of the disclosed embodiments are possible within the spirit and scope of the invention, and the invention should be construed to encompass such modifications.

We claim:

1. A stock system comprising: a butt stock assembly pivotable between an extended position and a folded position and including a pivoting stock frame and a latch mechanism operable to selectively lock the butt stock assembly in the extended position and the folded position; the latch mechanism comprising a latch arm having a detent member connected thereto and configured to lock the butt stock assembly in the folded position; a locking feature disposed along a firearm chassis to which the butt stock assembly is attached in a position for engagement by the latching mechanism, and wherein the locking feature is engaged by at least a portion of the latch arm when the butt stock assembly is in the folded position to lock the butt stock assembly in the folded position; wherein the latch arm is operable to remove the detent member from locking engagement, thereby enabling the butt stock assembly to be pivoted between its extended position and its folded position; and wherein the detent member is configured to engage a locking opening to lock the butt stock assembly in the extended position, and wherein the latch arm is operable to remove the detent member from engagement with the locking pocket to enable the butt stock assembly to be unlocked and pivoted from the extended position.

2. The stock system of claim **1**, wherein the detent member is biased into engagement with the locking pocket by a biasing member when the butt stock is in the extended position.

3. A firearm comprising: a chassis; a receiver located along the chassis; a barrel assembly mounted to the receiver and defining a chamber of the firearm adjacent the receiver; a bolt assembly having a bolt handle, the bolt assembly operable within the receiver for chambering and ejecting ammunition cartridges; and a butt stock assembly comprising a bolt handle opening positioned and configured to substantially enclose the bolt handle when the butt stock assembly is in the folded position, thereby securing and limiting movement of the bolt assembly when the butt stock assembly is in the folded position.

4. The firearm of claim **3** and wherein the bolt assembly comprises: an interchangeable bolt assembly having a bolt body slidably received within the receiver and defining an axial bore extending therethrough from a distal end to a proximal end; and wherein the barrel assembly comprises an interchangeable barrel assembly releasably mounted to the receiver.

5. The firearm of claim **4** and wherein the bolt assembly further comprises an interchangeable bolt head received within the axial bore at the proximal end of the bolt body; and wherein the firearm can be reconfigured to be operable with ammunition cartridges of multiple different calibers by interchanging the barrel and bolt head to adapt the firearm to fire different caliber ammunition.

6. The firearm of claim **4** and wherein the interchangeable barrel assembly comprises at least one substantially unitary barrel mounted to the receiver.

7. The firearm of claim **3** and further comprising a magazine well defined within the chassis and in communication with the chamber for feeding ammunition to the chamber; and a magazine receivable in the magazine well for holding ammunition.

8. A firearm comprising: a receiver; a chassis; a barrel connected to the receiver and defining a chamber adapted to receive an ammunition cartridge therein; a fire control including a trigger for initiating firing of the ammunition cartridge; and a foldable butt stock assembly connected to the chassis, the butt stock assembly having a butt stock pivotable between an extended position extending longitudinally with respect to the chassis, and a folded position wherein the butt stock assembly is located adjacent the chassis; and a latch mechanism comprising a latch arm and a detent member connected to the latch arm and configured to engage a portion of the chassis to selectively lock the butt stock in its extended position and its folded position; a magazine received in the chassis in communication with the receiver for supplying ammunition to the chamber; a hand guard assembly mountable along the chassis; and a wire management system along the chassis and including at least one wire channel adapted to receive a wire for connection of an accessory to the firearm.

9. The firearm of claim **8**, wherein the magazine comprises a magazine box and a spacer configured to be selectively inserted in the magazine box, wherein the magazine is configured to accommodate ammunition cartridges of a first length when the spacer is inserted in the magazine box, and wherein the magazine is configured to accommodate ammunition cartridges of a second length different from the first length when the spacer is not inserted in the magazine box.

10. The firearm of claim **8**, wherein the detent member is configured to engage a locking opening in the chassis to lock the butt stock in the extended position, and wherein the latch arm is operable to remove the detent member from engagement with the locking opening to enable the butt stock to be unlocked and pivoted from the extended position.

11. The firearm of claim **10**, wherein the detent member is biased into engagement with the locking opening by a biasing member when the butt stock is in the extended position.

12. The firearm of claim **11**, wherein the detent member and the biasing member are disposed in a transverse channel defined in the butt stock.

13. The firearm of claim **8**, and further comprising a locking feature disposed along the chassis in a position for engagement by the latching mechanism, and wherein the locking feature is engaged by a portion of the latch arm when the butt stock is in the folded position to lock the butt stock in the folded position.

14. The firearm of claim **8** and wherein the hand guard assembly comprises a plurality of platforms and at least one accessory rail mounted to at least one of the plurality of platforms and extending therealong in a position bridging the hand guard assembly and the receiver of the firearm.

15. The firearm of claim **8**, and further comprising: an interchangeable bolt assembly operable within a receiver of the firearm for chambering and ejecting ammunition cartridges in the firearm, the bolt assembly comprising a bolt body having a bolt handle, bolt head having an extractor for engaging ammunition cartridges within the chamber, and a firing pin operable by the fire control for engaging and firing an ammunition cartridge within the chamber.

16. The firearm of claim **8** and wherein the butt stock assembly further comprises an opening positioned and con-

figured to engage a bolt handle of a bolt assembly of the firearm when the butt stock is in the folded position, thereby substantially securing and limiting movement of the bolt assembly when the butt stock is in the folded position.

17. The firearm of claim 8 and wherein the wire management system comprises: at least one wire channel formed integrally with an outer wall of the chassis for receiving a wire for an electronic firearm accessory; and at least one clip configured to be secured within the at least one channel and adapted to receive the wire and secure the wire in the at least one wire channel.

18. The firearm of claim 17, wherein the at least one clip comprises: a top; a pair of deformable arms extending from the top; and a passage defined between the pair of deformable arms and configured to receive the wire.

19. The firearm of claim 8 and further comprising at least one accessory mounting rail comprising: a top surface for interfacing with an accessory; a bottom surface interfacing with the firearm; and at least one pair of lugs extending from the bottom surface and engaging an opening in the firearm, the at least one pair of lugs being formed integrally with the bottom surface and configured to transfer recoil forces generated during operation to the chassis.

20. The firearm of claim 8 and further comprising a caliber conversion assembly, comprising: a first barrel assembly having a barrel defining a chamber configured to receive ammunition of a first caliber, and configured to be interchanged with at least one second barrel assembly mountable on the firearm and having a second barrel defining a chamber configured to receive ammunition of a second caliber; a first bolt head configured to be interchanged with at least one second bolt head operable in the firearm, wherein the first and second bolt heads are removably securable to a bolt body operable within a receiver of the firearm; and at least one ammunition magazine for supplying ammunition cartridges of a desired caliber to the chamber of the firearm; wherein interchanging of the first barrel assembly and the first bolt head with the at least one second barrel assembly and the at least one second bolt head respectively, enables the firearm to be reconfigured to be operable with ammunition cartridges of different calibers without other modifications to the firearm.

21. The firearm of claim 20 and wherein the magazine comprises a plurality of ammunition magazines each configured for supplying ammunition of a desired different caliber.

22. The firearm of claim 8 and further comprising a magazine conversion block received within the chassis and adapted to receive a different size magazine therein to enable use of different ammunition magazines by the firearm.

23. A firearm comprising: a chassis; a receiver mounted within the chassis; a barrel assembly mountable to the receiver in operative engagement therewith and defining a chamber of the firearm for receiving ammunition therein; a bolt assembly operable within the receiver for chambering and ejecting ammunition cartridges, the bolt assembly comprising a bolt body adapted to be moveable along the receiver to chamber and eject ammunition cartridges; and a butt stock assembly connected to the chassis and comprising a butt stock having an opening, the butt stock being pivotable between an extended position and a folded position adjacent the chassis; wherein the opening of the butt stock is configured to receive and enclose a portion of the bolt assembly therein when the butt stock assembly is in its folded position, thereby substantially limiting movement of the bolt assembly when the butt stock assembly is in the folded position.

24. The firearm of claim 23, further comprising: a hand guard assembly at least partially located along the chassis and barrel assembly, the hand guard assembly substantially surrounding the barrel assembly and comprising a plurality of platforms including at least a top platform and a bottom platform; and a top accessory mounting rail mounted on the top platform and connected to a top portion of the receiver so as to substantially bridge the receiver and barrel assembly.

25. The firearm of claim 24, wherein the plurality of platforms comprises at least eight platforms, and wherein each platform defines a separate accessory mounting plane.

26. The firearm of claim 24, and further comprising: at least one additional accessory mounting rail mountable on the bottom platform or a side platform; and at least one recoil lug integrally formed with the at least one additional accessory mounting rail and receivable in at least one opening in the hand guard assembly, wherein the at least one lug is adapted to transfer recoil forces generated during operation to the chassis.

27. A folding stock assembly for a firearm, comprising: a pivoting butt stock moveable between an extended position extending longitudinally and a folded position; a latch mechanism operable to selectively lock the butt stock in its extended and folded positions, the latch mechanism comprising a latch arm, a locking opening and a detent member configured to engage the locking opening in locking engagement therewith for securing the butt stock in its extended position, the latch arm being moveable for disengaging the detent member from the locking pocket; and a locking mechanism located along the firearm in a position to be engaged by the latch arm when the butt stock is moved to its folded position for securing the butt stock in its folded position.

28. The folding stock assembly of claim 27 and further comprising an opening formed in the butt stock and configured to substantially enclose a portion of a bolt assembly of the firearm when the butt stock is in its folded position, thereby substantially limiting movement of a bolt assembly of the firearm when the butt stock is in its folded position.

29. The folding stock assembly of claim 27 and further comprising a biasing member for urging and substantially maintaining the detent member and locking opening in locking engagement.

30. The folding stock assembly of claim 27 and further comprising a hand guard assembly adapted to connect to a portion of the stock assembly and comprising a plurality of platforms each defining a separate accessory mounting plane, and at least one accessory rail mounted along at least one platform.

31. The folding stock assembly of claim 30 and further comprising at least one recoil lug for mounting the at least one accessory rail to its at least one platform of the hand guard assembly and adapted to transfer recoil forces to the hand guard assembly during operation.

32. The folding stock assembly of claim 27 and further comprising a hinge member pivotally connected to a hinge bracket mounted to the butt stock and to a chassis of the firearm, the hinge member being adjustable with respect to the hinge bracket to adjust the location of the locking opening with respect to the detent member.

33. A foldable butt stock assembly for a firearm, comprising: a stock body pivotable between an extended position extending longitudinally with respect to the firearm, and a folded position wherein a portion of the stock body is folded and located adjacent a remaining portion of the stock body; a

latch mechanism comprising a latch arm and a detent member connected to the latch arm and configured to selectively lock the stock body in its extended position and its folded position; wherein the stock body further comprises an opening formed therein at a location configured to receive and substantially retain a portion of a bolt assembly of the firearm; and whereby when the stock body is in its extended position, the latch arm is operable to remove the detent member from an engaged, locked position, thereby enabling the stock body to be pivoted between its extended and folded positions.

34. The foldable butt stock assembly of claim **33**, wherein the detent member is configured to engage a locking opening for locking the stock body in its extended position, and wherein the latch arm is operable to remove the detent member from engagement with the locking opening to enable the stock body to be unlocked and pivoted from its extended position to its folded position.

35. The foldable butt stock assembly of claim **34**, wherein the detent member is biased into engagement with the locking opening by a biasing member when the stock body is in its extended position.

36. The foldable butt stock assembly of claim **34**, and further comprising a hinge member pivotally connected to a hinge bracket mounted to the stock body and to a chassis of the firearm, the hinge member being adjustable with respect to the hinge bracket to adjust the location of the locking opening with respect to the detent member.

37. The foldable butt stock assembly of claim **33**, and further comprising a hand guard assembly adapted to connect to a portion of the butt stock assembly and comprising a plurality of platforms each defining a separate accessory mounting plane, and at least one accessory rail mounted along at least one platform.

* * * * *