

INSTRUCTION MANUAL FOR



RUGER PRECISION RIFLE™



– Rugged, Reliable Firearms® –



**READ THE INSTRUCTIONS AND
WARNINGS IN THIS MANUAL CAREFULLY
BEFORE USING THIS FIREARM**

© 2015 Sturm, Ruger & Co., Inc.

This manual may not be reproduced in whole or in part without the express written permission of Sturm, Ruger & Co., Inc.

**For Service on This Model Please Call:
(603) 865-2442 (See p. 46)**

THIS INSTRUCTION MANUAL SHOULD ALWAYS ACCOMPANY THIS FIREARM AND BE TRANSFERRED WITH IT UPON CHANGE OF OWNERSHIP, OR WHEN THE FIREARM IS LOANED OR PRESENTED TO ANOTHER PERSON

www.ruger.com

State-By-State Warnings

Certain states require by law that their own specified warning notices in larger-than-normal type be conspicuously included by the manufacturer, distributor or retailer with firearms sold in that state. Sturm, Ruger & Co., Inc. sells its products in compliance with applicable laws and regulations. Because our products may be sold in these states, we include the following:

California:

WARNING

“Children are attracted to and can operate firearms that can cause severe injuries or death. Prevent child access by always keeping guns locked away and unloaded when not in use. If you keep a loaded firearm where a child obtains and improperly uses it, you may be fined or sent to prison.”

ADVERTENCIA

“A los niños los atraen las armas de fuego y las pueden hacer funcionar. Ellos pueden causarse lesiones graves y la muerte. Evite que los niños tengan acceso a las armas de fuego guardándolas siempre con llave y descargadas cuando no las esté utilizando. Si usted tiene un arma de fuego cargada en un lugar en que un niño tiene acceso a ella y la usa indebidamente, le pueden dar una multa o enviarlo a la cárcel.”

Connecticut:

“UNLAWFUL STORAGE OF A LOADED FIREARM MAY RESULT IN IMPRISONMENT OR FINE.”

Florida:

“IT IS UNLAWFUL, AND PUNISHABLE BY IMPRISONMENT AND FINE, FOR ANY ADULT TO STORE OR LEAVE A FIREARM IN ANY PLACE WITHIN THE REACH OR EASY ACCESS OF A MINOR UNDER 18 YEARS OF AGE OR TO KNOWINGLY SELL OR OTHERWISE TRANSFER OWNERSHIP OR POSSESSION OF A FIREARM TO A MINOR OR A PERSON OF UNSOUND MIND.”

Maine:

“ENDANGERING THE WELFARE OF A CHILD IS A CRIME. IF YOU LEAVE A FIREARM AND AMMUNITION WITHIN EASY ACCESS OF A CHILD, YOU MAY BE SUBJECT TO FINE, IMPRISONMENT OR BOTH. KEEP FIREARMS AND AMMUNITION SEPARATE. KEEP FIREARMS AND AMMUNITION LOCKED UP. USE TRIGGER LOCKS.”

Maryland:

“WARNING: Children can operate firearms which may cause death or serious injury. It is a crime to store or leave a loaded firearm in any location where an individual knew or should have known that an unsupervised minor would gain access to the firearm. Store your firearm responsibly!”

Massachusetts:

“WARNING FROM THE MASSACHUSETTS ATTORNEY GENERAL: This handgun is not equipped with a device that fully blocks use by unauthorized users. More than 200,000 firearms like this one are stolen from their owners every year in the United States. In addition, there are more than a thousand suicides each year by younger children and teenagers who get access to firearms. Hundreds more die from accidental discharge. It is likely that many more children sustain serious wounds, or inflict such wounds accidentally on others. In order to limit the chance of such misuse, it is imperative that you keep this weapon locked in a secure place and take other steps necessary to limit the possibility of theft or accident. Failure to take reasonable preventive steps may result in innocent lives being lost, and in some circumstances may result in your liability for these deaths.”

“IT IS UNLAWFUL TO STORE OR KEEP A FIREARM, RIFLE, SHOTGUN OR MACHINE GUN IN ANY PLACE UNLESS THAT WEAPON IS EQUIPPED WITH A TAMPER-RESISTANT SAFETY DEVICE OR IS STORED OR KEPT IN A SECURELY LOCKED CONTAINER.”

New Jersey:

“IT IS A CRIMINAL OFFENSE TO LEAVE A LOADED FIREARM WITHIN EASY ACCESS OF A MINOR.”

New York City:

“THE USE OF A LOCKING DEVICE OR SAFETY LOCK IS ONLY ONE ASPECT OF RESPONSIBLE FIREARM STORAGE. FOR INCREASED SAFETY, FIREARMS SHOULD BE STORED UNLOADED AND LOCKED IN A LOCATION THAT IS BOTH SEPARATE FROM THEIR AMMUNITION AND INACCESSIBLE TO CHILDREN AND UNAUTHORIZED PERSONS.”

North Carolina:

“IT IS UNLAWFUL TO STORE OR LEAVE A FIREARM THAT CAN BE DISCHARGED IN A MANNER THAT A REASONABLE PERSON SHOULD KNOW IS ACCESSIBLE TO A MINOR.”

Texas:

“IT IS UNLAWFUL TO STORE, TRANSPORT, OR ABANDON AN UNSECURED FIREARM IN A PLACE WHERE CHILDREN ARE LIKELY TO BE AND CAN OBTAIN ACCESS TO THE FIREARM.”

Wisconsin:

“IF YOU LEAVE A LOADED FIREARM WITHIN THE REACH OR EASY ACCESS OF A CHILD YOU MAY BE FINED OR IMPRISONED OR BOTH IF THE CHILD IMPROPERLY DISCHARGES, POSSESSES, OR EXHIBITS THE FIREARM.”

* * * * *

Please check with your licensed retailer or state police for additional warnings which may be required by local law or regulation. Such regulations change constantly, and local authorities are in the best position to advise you on such legal matters.

FIREARMS SAFETY IS YOUR RESPONSIBILITY
**SAFETY MUST BE THE FIRST AND CONSTANT
CONSIDERATION OF EVERY PERSON WHO HANDLES
FIREARMS AND AMMUNITION.**

This Instruction Manual is designed to assist you in learning how to properly use and care for your **RUGER PRECISION RIFLE™**. Please contact us if you have any questions.

Only when you are certain you fully understand the manual and can properly carry out its instructions should you practice loading, unloading, etc. with live ammunition. If you have any doubts about your ability to handle or use a particular type of gun safely, you should seek supervised instruction. Such personalized instruction often is available from local gun retailers, gun clubs or police departments. If none of these sources can help, visit www.nra.org or write to the following address:

National Rifle Association
11250 Waples Mill Road
Fairfax, VA 22030-7400

The person possessing a gun has a full-time job. You cannot guess; you cannot forget. You must know how to use your firearm safely. **Do not use any firearm without having a complete understanding of its particular characteristics and safe use.** Remember: There is no such thing as a foolproof gun.

TABLE OF CONTENTS

	Page
State-By-State Warning	2
Locking Device Installation Instructions	7
General Information	9
Nomenclature	10
Operation of Safety	10
Unboxing Your Rifle	12
Ammunition	14
Magazines	15
Care and Cleaning of Magazine	17
To Load and Fire (With Magazine)	17
To Load and Fire (Without Magazine)	18
To Unload	20
To Clear a Malfunction ("Jam")	21
To Minimize Malfunctions ("Jams")	22
Stock Adjustment	23
Trigger Pull Weight Adjustment	28
Ruger Precision Rifle™ Accessories	30
Disassembly	34
Lower Receiver Disassembly	38
Reversing the Safety Selector Switch	39
Trigger Group	39
How to Clean the Trigger Group	40
Care and Cleaning	42
Reassembly	43
Storage	45
Service and Parts Policy	46
Shipping Firearms for Repair	46
Ordering Parts	47
Parts List	48
Exploded Views	51 - 54
The Basic Rules of Safe Firearms Handling	55
Warranty Information	60

"RUGER" is a registered U.S. trademark.



**WARNINGS OF GREAT IMPORTANCE ARE
FOUND ON THE FOLLOWING PAGES:**

Locking Devices	7	Unloading	21
Alterations	9	Malfunctions	22
Manual Safety	11	Folding Stock	23
Folding Stock	13	Disassembly	34
Ammunition	14	Lubrication	43
Lead Exposure	15	Storage	45
Loading	19	Shipping	46
Handling	19	Parts Purchasers	47

**OTHER CAUTIONS AND WARNINGS APPEAR
THROUGHOUT THE MANUAL.**

LOCKING DEVICE INSTALLATION INSTRUCTIONS



WARNING – USE OF LOCKING DEVICES



**Do not store keys
in lock.**

- Always keep your firearm pointed in a safe direction, including when you are installing or removing your locking device.
- Always verify that your firearm is completely **unloaded** before installing your locking device.
- Do **not** install locking devices in the trigger guard; always keep your fingers and locking device outside the trigger guard during device installation and removal.
- Store firearms, ammunition and keys separately and securely, away from children and careless adults; do **not** store your firearm with the keys in the locking device.
- Do not attempt to work the action of your firearm with the locking device in place; this may damage your firearm.
- While locking devices are an important aid to security measures, they are not a substitute for safe firearm handling and proper storage. Remember that any mechanical device can be bypassed with enough time, knowledge, determination and equipment.

**LOCKING DEVICES MUST BE USED
SAFELY AND RESPONSIBLY**

It is important to use the locking device on your Ruger® firearm!

Keep the muzzle pointed in a safe direction and your fingers outside the trigger guard at all times!

To Install the Factory-Supplied Locking Device:

1. Be sure the firearm and its magazine are completely unloaded and contain no cartridges or cartridge cases.
2. Open the action completely by drawing the bolt fully to the rear.
3. Remove the magazine by pressing the magazine release lever (just behind the magazine and in front of the trigger guard – see nomenclature, p. 10) forward, and pulling the magazine down and out of the rifle.
4. If the stock is unfolded, fold the stock so the bolt can be removed (see page 23).

5. If the bolt is in the upper receiver, remove the bolt by lifting the bolt handle upward, and then pulling the bolt rearward while depressing the rear portion of the bolt stop. (See step 7, page 35.)
6. Apply the lock to your **RUGER PRECISION RIFLE™** as shown below in Figure 1.
7. With the key turned to the farthest clockwise position, insert the loose end of the cable into the lock. Turn the key counterclockwise and remove the key.
8. Once the lock is securely closed, pull firmly on the lock to test the connection and be sure it is locked. **Do not leave or store your firearm with the key in the lock!** Store your locked, unloaded firearm and the key in secure, separate locations, away from ammunition, children and unauthorized adults.

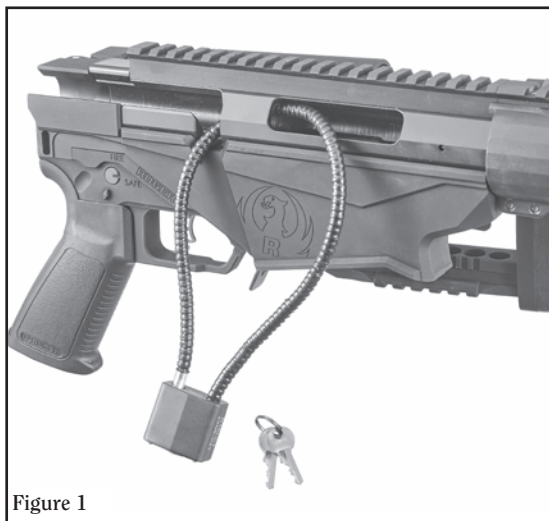

Figure 1

***Correct Installation of Cable Lock
For Ruger Precision Rifle™***

**FIREARMS ARE DANGEROUS WEAPONS
READ THE INSTRUCTIONS AND WARNINGS
IN THIS MANUAL THOROUGHLY AND CAREFULLY
BEFORE USING.**

 WARNING—ALTERATIONS	
	This product was designed to function properly in its original condition. Alterations can make it unsafe. Do not alter any part or add or substitute parts or accessories not made by Sturm, Ruger & Co., Inc.
	DO NOT ALTER ANY GUN

GENERAL INFORMATION AND MECHANICAL CHARACTERISTICS

The **RUGER PRECISION RIFLE™** is a bolt-action, magazine fed, repeating rifle. The assembly of the **RUGER PRECISION RIFLE™** is designed to produce a direct recoil path through the upper receiver into the butt stock, without the use of traditional bedding. Materials used in the **RUGER PRECISION RIFLE™** are steel and aircraft grade aluminum. Styling and features of the **RUGER PRECISION RIFLE™** have been carefully crafted to accommodate Ruger® and other aftermarket accessories designed for use on modern sporting-type rifles.

Notable features of the **RUGER PRECISION RIFLE™** include: a new externally adjustable trigger; a magazine latching system that accepts two different magazine types: (1) M110/SR25/DPMS/Magpul®, and (2) AICS; a folding stock with adjustment for length of pull and comb height; and a 20 MOA canted scope base.

NOMENCLATURE

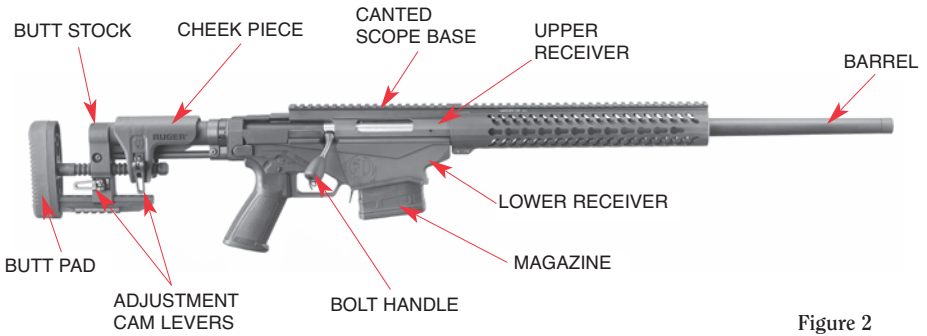

Figure 2

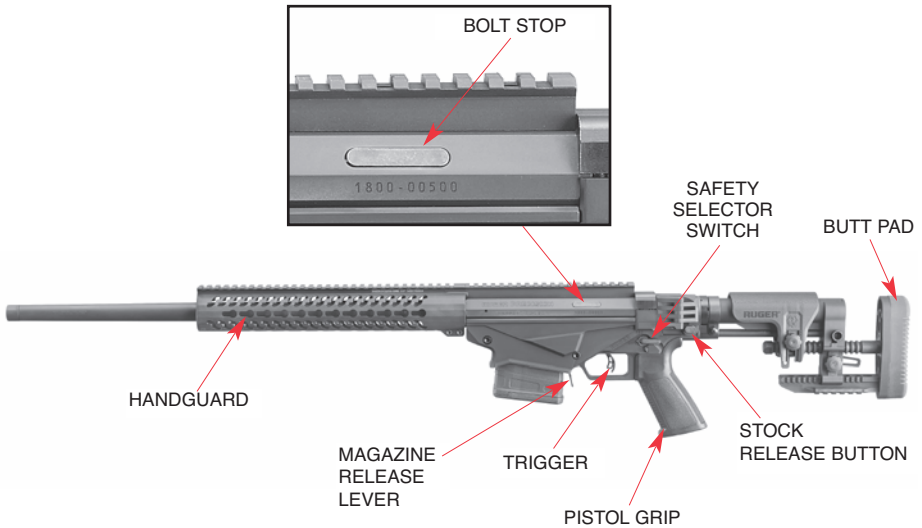

Figure 3 – In these illustrations the frequently used operating components are identified.

OPERATION OF SAFETY

The manual safety mechanism on the **RUGER PRECISION RIFLE™** is located on the left side of the lower receiver rearward of the trigger. The safety selector switch can be moved from the “FIRE” position to the “SAFE” position only when the firing pin is cocked. (Fully raising the bolt handle cocks the firing pin.) The safety selector switch is “on” when it is in a fully horizontal position pointing to the word “SAFE.” (See Figure 4, p. 11.) When the safety is on “SAFE,” it blocks the trigger. The “FIRE” position is reached by rotating the lever towards a vertical position. The lever will stop when the pointer reaches the word “FIRE.”

WARNING: When manipulating the safety selector switch, **KEEP YOUR FINGERS OUTSIDE THE TRIGGER GUARD!** When the safety selector switch is in the “FIRE” position and the trigger is pulled, the rifle will fire.

The safety should be kept on “SAFE” at all times except when actually firing.

If the safety selector switch does not function properly, or it seems to move too easily, or it does not seem firmly positioned in either the “SAFE” or “FIRE” position, the rifle should not be used. It should be returned to the Newport Customer Service Department for repair (see page 46).

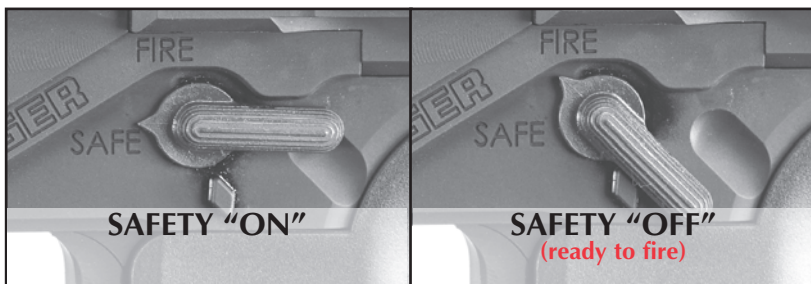



Figure 4

 <h2 style="margin: 0;">WARNING – MANUAL SAFETY</h2>	
 <p style="text-align: center;">Safety in “SAFE” Position</p>	<p>Keep the safety selector switch in the “SAFE” position unless actually firing. Always move the safety selector switch fully to its intended position and <u>check</u> it. The safety selector switch must be rotated fully to the “SAFE” position for the safety to be “on.” Never depend on a safety mechanism or any other mechanical device to justify careless handling or permitting the rifle to point in an unsafe direction. The only “safe” rifle is one in which the bolt is open, the chamber is empty, and there is no magazine in the gun.</p>
KNOW HOW TO USE THE SAFETY	

UNBOXING YOUR RIFLE

General Contents

IMPORTANT NOTICE

WHEN ORIGINALLY SHIPPED FROM THE FACTORY, YOUR RUGER PRECISION RIFLE™ BOX, AND CONTENTS, WERE IN PERFECT CONDITION TO ENSURE SAFE DELIVERY.

IF THIS BOX IS USED FOR RESHIPMENT OF THE ORIGINAL CONTENTS, IT SHOULD BE REINFORCED AND HANDLED CAREFULLY TO PREVENT DAMAGE IN TRANSIT.

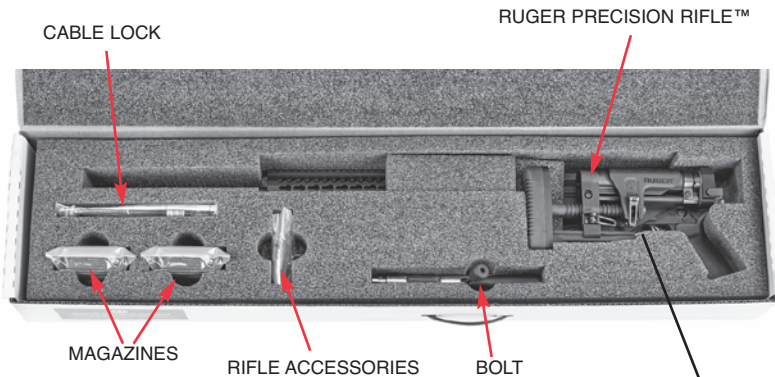

1. **Keep the muzzle pointed in a safe direction and your fingers outside the trigger guard at all times!**
2. Lift butt stock (rotate 90° upward). See Figure 5.
3. Grasp the butt pad and lift the rifle until it emerges from its nested cavity in the packaging. At this point, keep the butt stock folded so the bolt can be inserted into the receiver.

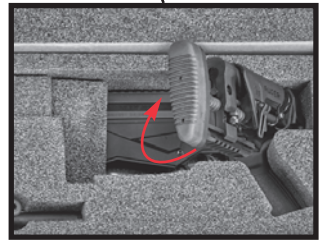

Figure 5

4. **Be sure the firearm and its magazine are completely unloaded and contain no cartridges or cartridge cases! At this point, no magazine should be in the rifle.**
5. Reference “Operation of Safety” section, p. 10. Rotate the safety selector switch to its full horizontal position with the pointer facing the word “SAFE.” If you do not plan to utilize your firearm immediately, Ruger recommends applying the locking device to the rifle. Please see “Locking Device Installation Instructions,” p. 7. If you will be using the rifle, please continue to step 6.

6. Remove the rifle bolt from its nested cavity and insert it into the upper receiver as shown in Figure 6.

In order to insert the bolt into the upper receiver, the bolt handle must be at the two o'clock position and the lobe of the cocking piece must be in the six o'clock position. If this is not the case, grasp the entire bolt shroud firmly and rotate it clockwise until the lobe and handle are in the correct positions (see Figure 7). Tilt the rifle so the muzzle end faces downward (in a safe direction) to aid in this process. The bolt handle must be oriented towards the bolt channel on the right hand side of the upper receiver.

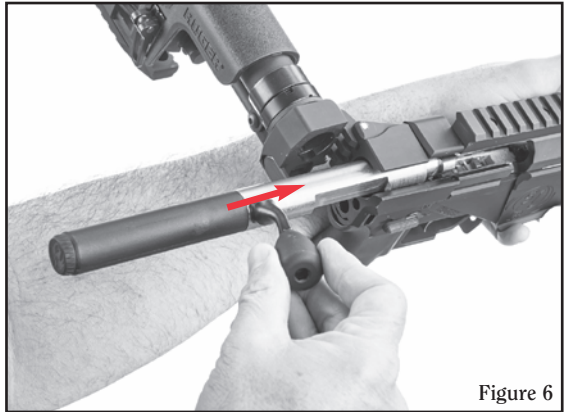
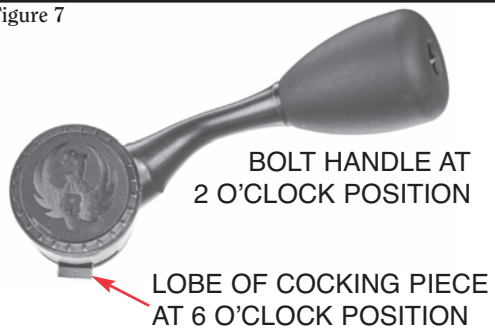

Figure 6

Figure 7



BOLT HANDLE AT
2 O'CLOCK POSITION

LOBE OF COCKING PIECE
AT 6 O'CLOCK POSITION

7. Continue to run the bolt to its forwardmost position, then rotate the bolt handle down to lock the bolt closed. Please note that the bolt must be in its forwardmost position and not protruding from the back of the upper receiver before the stock is closed. Closing the stock with the bolt protruding from the upper receiver can result in damage to your rifle.



WARNING – FOLDING STOCK



The bolt on your Ruger Precision Rifle™ should always be in the forwardmost and locked (handle down) position when folding or opening the stock. Failure to fully close the bolt may result in damage to the bolt shroud or bolt.



**CLOSE BOLT
BEFORE FOLDING
OR OPENING STOCK**

8. Unfold the butt stock until it aligns with the upper receiver and snaps into place. An audible “click” will be heard as the pivot latch engages.
9. Raise the bolt handle and retract the bolt fully.
10. **Be sure the firearm and its magazine are completely unloaded and contain no cartridges or cartridge cases! At this point, no magazine should be in the rifle.**
11. Your rifle is now assembled. Please continue reading this manual to familiarize yourself with the features and functions of your **RUGER PRECISION RIFLE™**.

AMMUNITION

The **RUGER PRECISION RIFLE™** is chambered for many of the most popular factory-loaded cartridges manufactured in accordance with U.S. Industry practice. The particular caliber for each rifle is marked on the barrel. Use cartridges only of the designated caliber marked on the barrel. Please see “Warning - Ammunition” below and “Warning - Loading” on page 19.

USE ONLY FACTORY AMMUNITION LOADED TO U.S. INDUSTRY STANDARDS

 <h2 style="margin: 0;">WARNING – AMMUNITION</h2>	
	<p>Death, serious injury and damage can result from the wrong ammunition, bore obstructions, powder overloads or incorrect cartridge components. Even the strongest gun can be “blown up” as a result of excess pressure. <u>Always</u> wear shooting glasses and hearing protection.</p>
	<p>IMPROPER AMMUNITION DESTROYS GUNS</p>

AMMUNITION (CARTRIDGES) NOTICE

WE SPECIFICALLY DISCLAIM RESPONSIBILITY FOR ANY DAMAGE OR INJURY WHATSOEVER OCCURRING IN CONNECTION WITH, OR AS THE RESULT OF, THE USE IN RUGER FIREARMS OF FAULTY, OR NON-STANDARD, OR “REMANUFACTURED” OR HAND LOADED (RELOADED) AMMUNITION, OR OF CARTRIDGES OTHER THAN THOSE FOR WHICH THE FIREARM WAS ORIGINALLY CHAMBERED.



WARNING – LEAD EXPOSURE



Discharging firearms in poorly ventilated areas, cleaning firearms, or handling ammunition may result in exposure to lead and other substances known to the State of California to cause birth defects, reproductive harm, and other serious physical injury. Have adequate ventilation at all times. Wash hands thoroughly after exposure.

**SHOOTING OR CLEANING GUNS
MAY EXPOSE YOU TO LEAD**

MAGAZINES

The **RUGER PRECISION RIFLE'S™** patented magazine latching system accepts two different magazine types: (1) M110/SR25/DPMS/Magpul®, and (2) AICS. Ruger has tested these magazine types and selected the 10-round, Magpul® PMAG® 10 LR/SR GEN M3 magazine to ship with this rifle.

The correct caliber for your rifle is marked on the barrel and, although this magazine is marked 7.62 x 51 you should only load it with cartridges of the correct caliber for your rifle. As always, Ruger recommends use of only high-quality magazines that are clean and in good working order.

Magazines that have been tested and approved for use with the **RUGER PRECISION RIFLE™** are available through our Sportswear & Accessories Sales Department, Monday through Friday, 7:30 a.m. - 6:00 p.m. EST at 1-888-220-1173 ET or 24 hours a day, 7 days a week on the web at www.ShopRuger.com.



Magpul® PMAG® 10 LR/SR GEN M3



AICS MAGAZINE

**DAMAGED, NON-STANDARD OR IMPROPERLY ASSEMBLED
MAGAZINES SHOULD NOT BE USED. THEY CAN CAUSE THE
RIFLE TO MALFUNCTION.**

INSERTING THE MAGAZINE

Practice the important aspects of gun handling described below (with an unloaded rifle) until you can perform each of the steps with skill and confidence. Before loading the rifle, please read completely through this manual and be certain the muzzle is pointing in a safe direction. Do not load the rifle until you are ready to use it! The rifle may be loaded with the bolt in the open (fully to the rear) or closed position, but loading in the open position is the preferred method because the chamber condition can be readily and continually determined, and it requires less force to insert a loaded magazine into the rifle with the bolt in the open (rearward) position.

1. Keep the muzzle pointed in a safe direction (see Rule 2, p. 55).
2. Position the safety selector switch in the “SAFE” position (see Figure 4, p. 11).
3. Hold the magazine as shown in Figure 8 and insert it all the way up into the magazine well. An audible “click” should be heard and felt as the magazine latch engages.
4. Check to be sure that the magazine is securely latched into place by pulling down on the magazine.

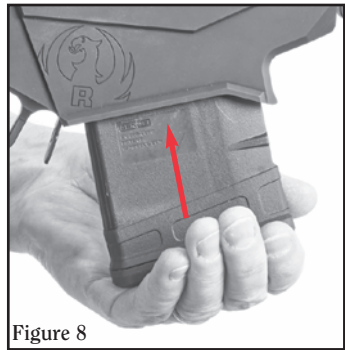

REMOVING THE MAGAZINE

1. Keep the muzzle pointed in a safe direction (see Rule 2, p. 55).
2. Position the safety selector switch in the “SAFE” position (see Figure 4, p. 11).
3. Hold the magazine as shown in Figure 9 by gripping the magazine and the magazine release lever together. Squeeze the lever towards the magazine to disengage the latch. As you squeeze the lever, you will feel it move through two stages; you may encounter heavier resistance releasing the second stage. (This is normal for a side latching magazine.)

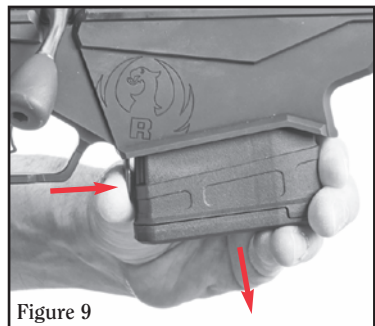

4. Once the magazine release lever has stopped, begin pulling down on the magazine, allowing your thumb to slide off the lever. To minimize the possibility of damage and malfunctions, do not let the magazine drop to the ground.

LOADING THE MAGAZINE

Use only clean, dry ammunition of the proper caliber in good condition and manufactured to U. S. Industry specifications. (See Notice and Warnings in other sections of this manual pertaining to Ammunition).

With the narrow end of the magazine facing forward, place a round between the feed lips of the magazine with the bullet tip forward. (See Figure 10.) Press the round down until it is held by the feed lips. Be sure to slide the round rearward until it is seated against the back of the magazine. Place the next round on top and repeat until the desired number of cartridges are loaded or the magazine is fully loaded.

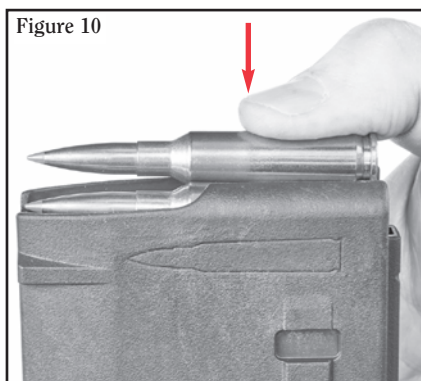

CARE AND CLEANING OF MAGAZINE

Check the magazine frequently to ensure that the follower moves freely and has adequate spring tension so that each cartridge is quickly raised to the feeding position.

To test the spring tension, load one cartridge into the magazine and then firmly press against the cartridge case. Remove your finger quickly. The cartridge should instantly and fully move into the feeding position. If it does not, the magazine should be cleaned. **If cleaning does not restore proper spring tension, do not use the magazine.** (NOTE: After testing, remove the test cartridge.)

When cleaning is necessary, use a solvent that will not harm the polymer or metal components.

TO LOAD AND FIRE (WITH MAGAZINE)

1. Keep the muzzle pointed in a safe direction (see Rule 2, p. 55).
2. Position the safety selector switch in the “SAFE” position (see Figure 4, p. 11).
3. Lift the bolt handle and draw the bolt fully to the rear.
4. Insert loaded magazine (see Figure 8, p. 16). Do not chamber a cartridge until you are ready to shoot.
5. Push the bolt handle forward. This will strip a cartridge from the magazine and push the cartridge ahead of the bolt into the chamber.

6. Close the bolt handle fully downward and keep the safety selector switch in the “SAFE” position. If it is desired to “top off” the magazine, the magazine may be removed, an additional cartridge loaded into the magazine, and the magazine inserted back into the rifle.
7. With a cartridge now chambered and the rifle pointed in a safe direction, rotate the safety selector switch into the “FIRE” position. Pulling the trigger will fire the cartridge. Always be certain that you are aware of your backstop and know where the bullet will strike when you fire the rifle.
8. Once the rifle has discharged, you may cycle the bolt to eject the spent case and chamber another round for firing.
9. Once the desired number of rounds have been fired, raise the bolt handle and draw the bolt fully to the rear.
10. Position the safety selector switch in the “SAFE” position (see Figure 4, p. 11). Note that cocking the firing pin by lifting the bolt handle is required to allow the rifle to enter the “SAFE” mode.

TO LOAD AND FIRE (WITHOUT MAGAZINE)

1. Keep the muzzle pointed in a safe direction (see Rule 2, p. 55).
2. Position the safety selector switch in the “SAFE” position (see Figure 4, p. 11).
3. Lift the bolt handle and draw the bolt fully to the rear.
4. **Do not chamber a cartridge until you are ready to shoot.** When you are ready to shoot, place a cartridge directly into the chamber. Push the bolt handle forward.
5. Close the bolt handle fully downward and keep the safety selector switch in the “SAFE” position. An empty, partially loaded, or fully loaded magazine may then be inserted into the rifle if desired.
6. With a cartridge chambered and the rifle pointed in a safe direction, rotate the safety selector switch into the “FIRE” position. Pulling the trigger will fire the cartridge. Always be certain that you are aware of your backstop and know where the bullet will strike when you fire the rifle.
7. Once the desired number of rounds have been fired, raise the bolt handle and draw the bolt fully to the rear. Note that cocking the firing pin by lifting the bolt handle is required to allow the rifle to enter the “SAFE” mode.
8. Position the safety selector switch in the “SAFE” position (see Figure 4, p. 11).



WARNING – LOADING



Know the caliber of your rifle you are loading and load cartridges of only that caliber into it!

Before loading, be certain the primer of each cartridge is seated flush with, or below, the surface of the cartridge case base. A cartridge discharged by the closing of the bolt can result in possible serious injury to the shooter and those nearby.

If a cartridge does not chamber readily, do not force it. Check the bore and chamber to be certain that each cartridge is the proper caliber and of correct dimensions. If you cannot determine why the cartridge will not fit, clear the rifle of all cartridges and write or call the factory.

The wrong ammunition can destroy your gun and result in serious injury.



**BE SURE WHAT YOU LOAD
IS THE CORRECT CALIBER**



**WARNING: DO NOT TOUCH THE TRIGGER
UNTIL YOU ARE ACTUALLY READY
TO FIRE THE RIFLE.**



WARNING – HANDLING

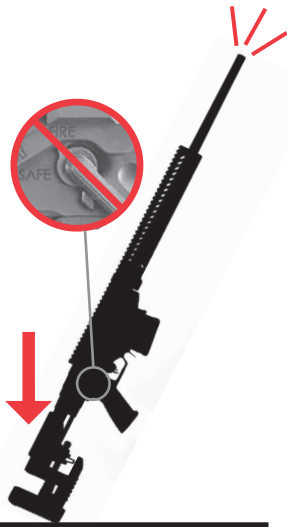

Never carry the rifle loaded with the safety selector switch in the “FIRE” position. If dropped or struck with the safety off, the rifle may fire. Such a discharge can occur with or without the trigger being directly struck or touched. **Never rest a loaded rifle against any object (wall, fence, vehicle, tree, etc.)** because there is always the possibility that the rifle will be jarred or slide from its position and fall with sufficient force to discharge. **Keep the safety on unless actually firing.**

**ANY GUN MAY FIRE IF
DROPPED**

TO UNLOAD

WARNING: This sequence must be followed exactly as spelled out. Failure to do so can result in the rifle's chamber becoming unintentionally loaded with a cartridge!

1. Keep the muzzle pointed in a safe direction at all times and keep your fingers outside the trigger guard.
2. Move the safety selector switch to the "SAFE" position if the firing pin is cocked (see Figure 4, p. 11).
3. Remove the magazine. REMEMBER that even though the magazine has been removed, a cartridge remaining in the chamber can still be fired!
4. Raise the bolt handle and draw the bolt fully to the rear, extracting and ejecting any cartridge in the chamber.
5. Position the safety selector switch in the "SAFE" position (see Figure 4, p. 11). Note that cocking the firing pin by lifting the bolt handle is required to place the safety selector switch in the "SAFE" mode.
6. Always visually double check the chamber to be certain it is empty. At this point, no magazine should be in the rifle.

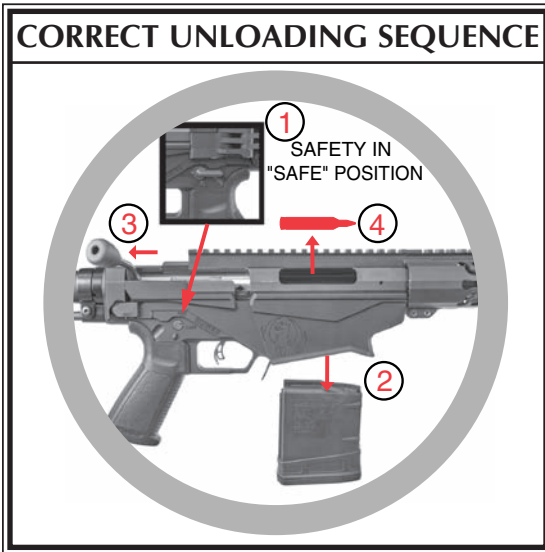

⚠ WARNING – UNLOADING



Removing the magazine or removing cartridges from the magazine does not prevent the rifle from being fired! When there is a cartridge in the chamber and the safety selector switch is in the “FIRE” position, the cartridge will discharge if the trigger is pulled. It is absolutely essential for the user to know how to completely unload the rifle. “Completely” means emptying the magazine and removing a chambered cartridge. **The safety selector switch should always be in the “SAFE” position when the rifle is being unloaded.** See the “Operation of Safety” section of this manual, page 10.

**GUN WILL FIRE WITH
MAGAZINE REMOVED OR
WITH EMPTY MAGAZINE**



TO CLEAR A MALFUNCTION (“JAM”)

If a jam occurs, immediately put the safety selector switch in the “SAFE” position and be certain the muzzle of the rifle is at all times pointing in a safe direction.

Study the situation to determine the nature of the jam and how best to clear it.

- If a cartridge or fired case is caught between the bolt and the barrel, or against a cartridge that is in the chamber, remove the magazine and retract the bolt fully. Now remove the jammed cartridge or case. If there is a cartridge in the chamber, remove it.
- When attempting to extract a cartridge that is “stuck” in the chamber, do not use any type of tool that is likely to act as a “firing pin” and fire the cartridge should the tool impact the primer.
- After clearing a jam, inspect the gun’s mechanism to determine if dirt might be the cause of the problem. Excess lubricant or grease can cause cartridges to feed sluggishly or fail to extract. An accumulation of grease or dirt on the face of the bolt, under the extractor, in the chamber, or in the magazine can contribute to cartridge feeding problems. See section on “Care and Cleaning” page 41.
- After clearing a jam, inspect all cartridges that have been removed from the gun. Safely dispose of any cartridges which are in any way damaged.
- If it appears that the rifle is not at fault and that the jam was caused by the type of cartridge being used, then try another type.
- Examine your fired cartridge cases. If they have split, blown or bulged heads, stop using that ammunition and promptly return the rifle to the factory for examination.

- If the above procedures do not result in a smooth and reliable feeding firearm, do not use the rifle. The **RUGER PRECISION RIFLE™** can be returned directly to our Newport Customer Service Department for inspection and repair, if required. See the “Service and Parts Policy” section of the manual for packing and shipping information on page 46.

 WARNING – MALFUNCTIONS	
	<p>If a cartridge hangs up, jams, or binds when being chambered or when being fed from the magazine into the chamber, do not attempt to force it into the chamber by pushing or striking the bolt handle.</p> <p>Most failures of a cartridge to feed or to chamber are caused by improper loading of the magazine or ammunition that is incorrect or defective.</p> <p>Whatever the cause, the user must, above all, recognize that jams can result in the potentially very dangerous situation of a cartridge firing before it is chambered. If this occurs, the cartridge case will rupture and its fragments will fly out of the gun with sufficient force to cause injury. Always wear shooting glasses and hearing protection!</p>
	STRIKING PRIMER CAN BURST CARTRIDGE

TO MINIMIZE MALFUNCTIONS (“JAMS”)

Firearms of all makes and types are susceptible to occasional malfunctioning due to a cartridge not feeding from the magazine to the chamber, or due to a cartridge or fired case not being extracted and ejected.



To minimize the possibility of such occurrences the gun user should:

- Use ammunition of the correct caliber and type which is loaded to U.S. Industry Specifications. Do not use cartridges that are deformed or cartridges that have been reloaded.
- Clean and lubricate the gun in accordance with the instructions in this manual.
- Learn to correctly operate the bolt and how to properly load and empty the chamber and magazine.
- **If the mechanism shows signs of not functioning correctly, or if a part is damaged or broken – do not use the rifle. Have it inspected and repaired.**

For most repairs, we recommend that Ruger® guns be returned to the factory. However, if a gun has a cartridge in it which cannot be removed, then it is a violation of Federal Regulations to ship that loaded gun whether it be by U.S. Mail or by common carrier. Contact our Newport Customer Service Department at (603) 865-2442.

STOCK ADJUSTMENT

The **RUGER PRECISION RIFLE™** has a folding butt stock that is adjustable for length of pull and comb height.

 WARNING – FOLDING STOCK	
	<p>The bolt on your Ruger Precision Rifle™ should always be in the forwardmost and locked (handle down) position when folding or opening the stock. Failure to fully close the bolt may result in damage to the bolt shroud or bolt.</p>
	<p>CLOSE BOLT BEFORE FOLDING OR OPENING STOCK</p>

To Fold the Stock:

1. **Keep the rifle pointed in a safe direction!** Put the safety selector switch in the “SAFE” position (see Figure 4, p. 11).
2. **CHECK TO BE CERTAIN THAT THE CHAMBER AND MAGAZINE ARE EMPTY.** Remove the magazine.
3. Close the bolt.
4. Push the stock release button (see Figure 11) and fold the stock fully to the left (see Figure 12).

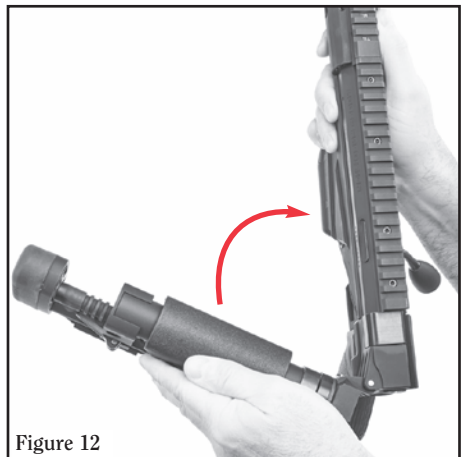
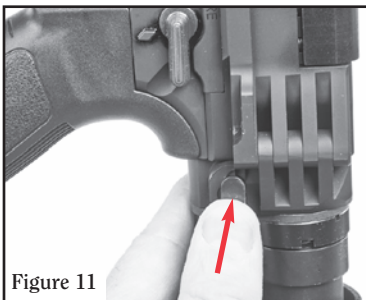

Rotate the tab (opposite) end of the stock release button clockwise $\frac{1}{4}$ turn to lock the stock in the folded position (see Figure 13).

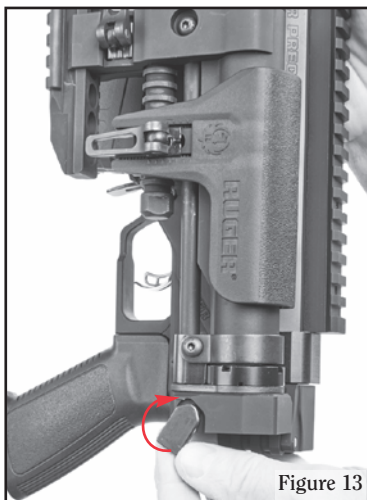

Figure 13

To Unfold the Stock:

1. **Keep the rifle pointed in a safe direction!** Put the safety selector switch in the “SAFE” position.
2. **CHECK TO BE CERTAIN THAT THE CHAMBER AND MAGAZINE ARE EMPTY.** Remove the magazine.
3. Be certain the bolt is fully closed and locked.
4. Rotate the tab end of the stock release button counterclockwise $\frac{1}{4}$ turn to unlock the stock. Unfold the stock until it snaps in place and locks.

To Adjust Length of Pull:

1. To adjust the length of pull, release the cam lever on the cheek piece and the cam lever on the stock frame (see Figure 14). The entire butt pad assembly can be moved in or out to lengthen or shorten the length of pull (see Figure 15). Note that the butt pad and the cheek piece will move together when both cam levers are released.

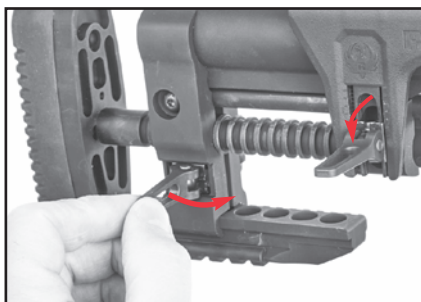

Figure 14

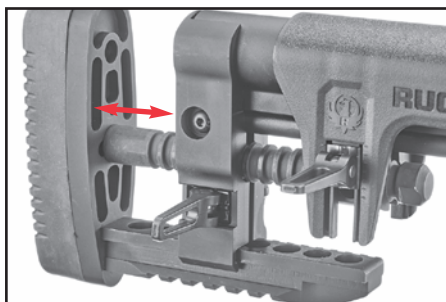
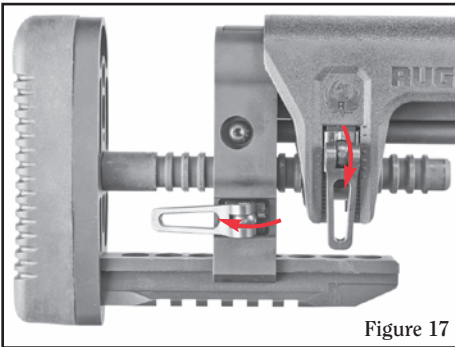
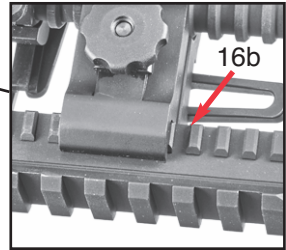
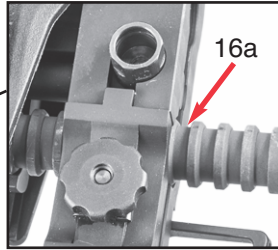
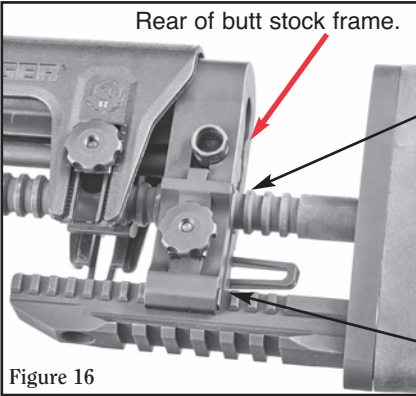

Figure 15

2. To lock the butt pad in place, both the cutout in the horizontal rod (see Figure 16a) and the indexing lugs on the lower picatinny rail (see Figure 16b) must be aligned with the rear of the butt stock frame (see Figure 16). Each increment adjusts the length of pull by $\frac{1}{4}$ of an inch. The length of pull should be set before adjusting the height of your cheek piece.
3. Lock down the two cam levers (see Figure 17).



Adjusting Cheek Piece:

1. Release the cheek piece cam lever (see Figure 18).

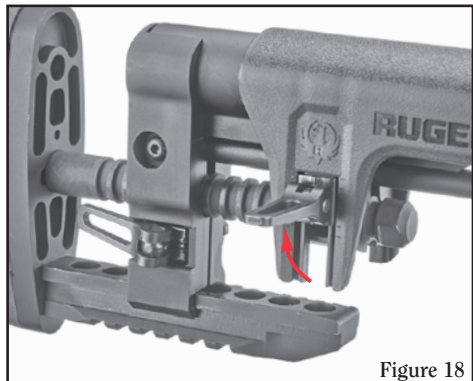

2. Gently squeeze the cheek piece on the Ruger Eagle logo (see Figure 19).
3. Move the cheek piece up or down to the desired height. Each “click” is 1/16 of an inch (see Figure 19).
4. Lock the cam lever (see Figure 20).
5. The cheek piece cam lever can lock either upward or downward, and should be locked in such a manner as to facilitate release at a later time.

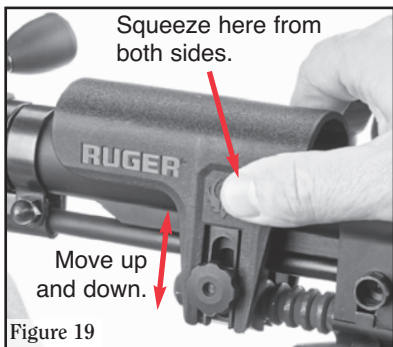

Figure 19

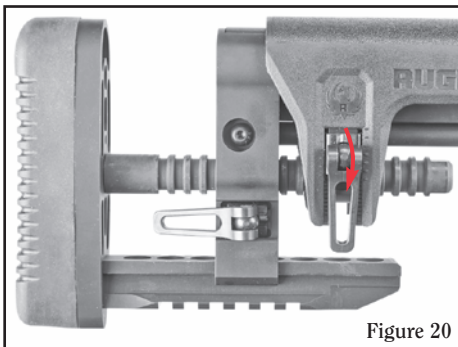

Figure 20

6. In order to move the cheek piece fore and aft, you must first free the cheek piece by releasing the cam lever and rotating it 180°. Now move the cheek piece fore or aft to the desired location. Finally, rotate the cam lever back 180° and lock it down. (See Figure 21.)

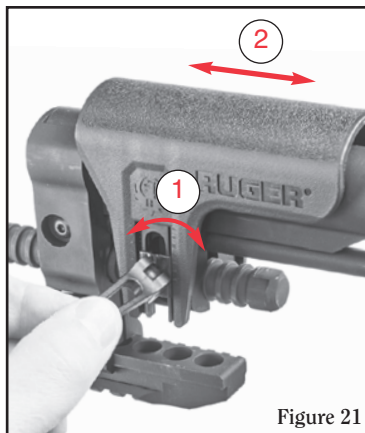

Figure 21

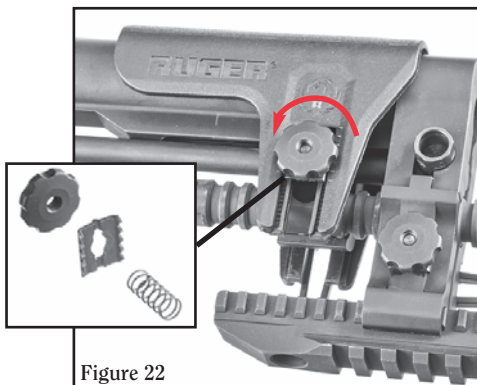

Figure 22

To Move Cheek Piece Toggle Lever to Other Side of Stock:

1. The cheek piece cam lever can be moved to the other side of the stock. To switch the cheek piece cam lever, release the cam lever, and remove the nut, washer and spring from the cheek piece. (See Figure 22.)

- Next, remove the cam lever, spring, and washer from the other side of the cheek piece (see Figure 23).

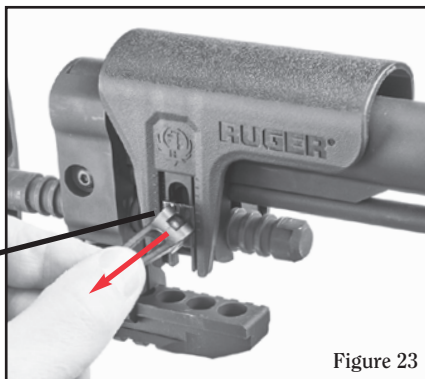

Figure 23

- Reassemble from the other side.

NOTE: Cam levers should be secure, but they should not be overtightened. If the cam levers are too tight, release the cam lever, loosen the nut on the opposite side a quarter turn, and lock the cam lever down to check the tension. Repeat until the cam lever tightens easily and keeps the butt stock and cheek piece firmly in place.

- The contact portion of the cheek piece can be adjusted fore and aft by removing the cheek piece, rotating it 180°, and reinstalling it. (See Figure 24.)

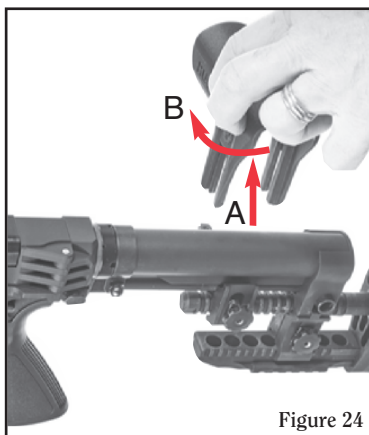

Figure 24

Cant Angle of the Butt Pad:

- Make sure both cam levers are locked (see Figure 20, p. 26).
- Using a 9/64" Allen wrench, remove the two screws on the back of the butt pad and remove the butt pad. (See Figure 25.)

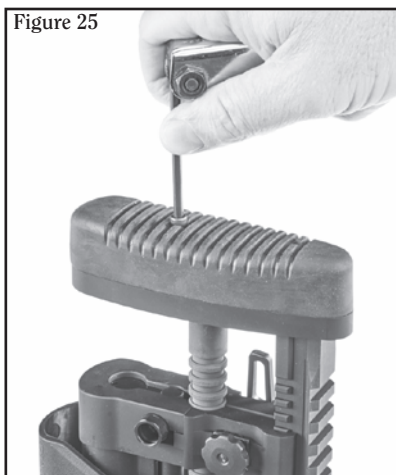
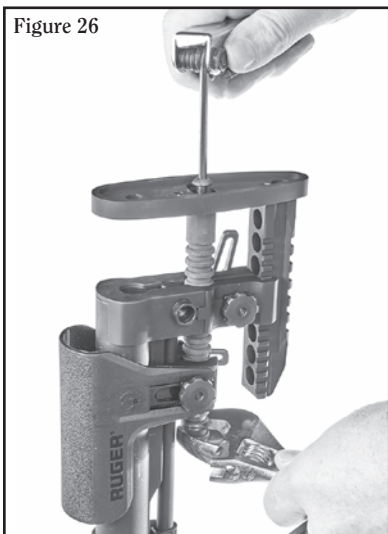

Figure 25

- Using a 5/32" Allen wrench on the middle screw of the butt pad frame and a 1/2" open end wrench on the front of the length of pull rod, loosen and remove the center screw from the butt pad frame. (See Figure 26.)
- Using a 5/32" Allen wrench, loosen the lower butt pad frame screw. (See Figure 27.)



- The cant of the butt pad can be adjusted either 9 degrees left or right by changing the hole that the middle butt pad screw passes through. Select the desired cant and insert the middle butt pad screw.
- Re-install the lower butt pad frame screw using a 5/32" Allen wrench.
- Tighten the middle butt pad frame screw with a 1/2 inch open end wrench and a 5/32" Allen wrench.
- Reinstall the recoil pad using a 9/64" Allen wrench.

TRIGGER PULL WEIGHT ADJUSTMENT

The trigger pull weight on the **RUGER PRECISION RIFLE™** can be adjusted from approximately 2 1/4 - 5 pounds.

To Adjust the Trigger:

- Keep the muzzle pointed in a safe direction at all times and keep your fingers outside the trigger guard.
- Move the safety selector switch to the "SAFE" position if the firing pin is cocked. Note that cocking the firing pin by lifting the bolt handle is required to allow the rifle to enter the "SAFE" mode.
- Remove the magazine. **REMEMBER that even though the magazine has been removed, a cartridge remaining in the chamber can still be fired!**

4. Raise the bolt handle and draw the bolt fully to the rear, extracting and ejecting any cartridge in the chamber.
5. Position the safety selector switch in the “SAFE” position (see Figure 4, p. 11).
6. Always visually double check the chamber to be certain it is empty. At this point no magazine should be in the rifle.
7. Rotate the rifle so that the magazine opening in the lower receiver is facing upwards.
8. Locate the slot running through the magazine release lever. Using a 5/64” Allen wrench, insert the long end into that slot and down into the square passageway in the lower receiver (see Figure 28). (Note: An Allen wrench for this operation is supplied in the bolt shroud located on the back of the rifle bolt.)
9. The adjusting screw is treated with a thread locking compound and may be difficult to move. Threading the screw in (turning clockwise) will increase the trigger pull weight, threading the screw out (turning counterclockwise) will reduce the trigger pull weight. Approximately six full turns of the screw represents the entire range of trigger pull weight adjustability. Turning the screw beyond this amount will not further increase or decrease trigger pull weight.

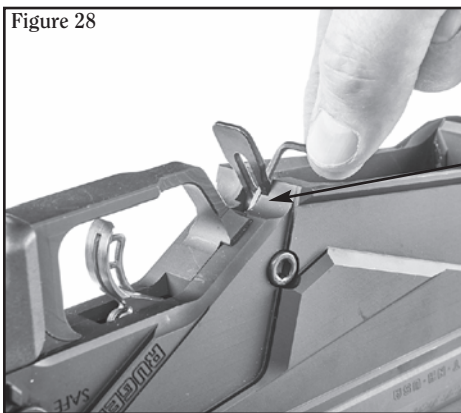

10. We suggest turning the screw in no more than 1/2 revolution increments and testing the pull weight before further adjustment is attempted. Repeat the steps outlined above as required to reach desired pull weight.

We suggest you familiarize yourself with the trigger's pull weight by dry firing (ensure the magazine is removed, the chamber is empty, and the rifle remains pointed in a safe direction) the rifle after a trigger pull weight adjustment, before live ammunition is fired.

Always visually double check the chamber to be certain it is empty prior to dry fire.

RUGER PRECISION RIFLE™ ACCESSORIES

Quick Detach Sling Mount Installation:

Your **RUGER PRECISION RIFLE™** comes with several quick detach (QD) mounting locations. There is one on the left side of the adjustable stock (see Figure 29), one on the back of the lower receiver when the stock is folded (see Figure 30), and one on the recoil pad back plate (see Figure 31). A QD sling mount (purchased separately) can be installed by pressing the center button on the sling mount (see Figure 32), and inserting it in any of the QD mounting locations on the rifle. (Operation of the sling mounts may vary, consult the instructions with the sling mount for specific information.)

To remove the QD sling mount, simply press the center button and pull it out of the stock. (See Figure 32.)

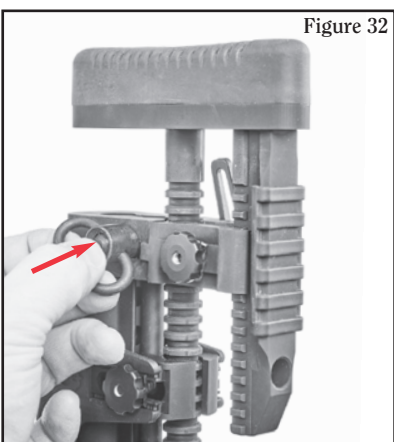
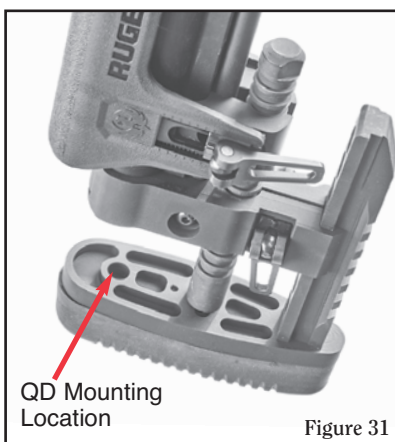
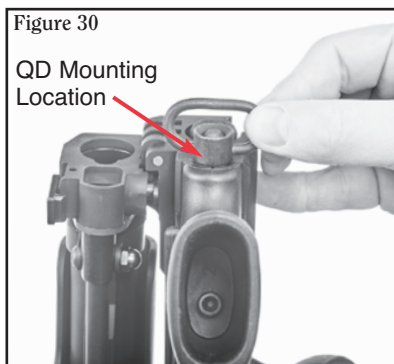
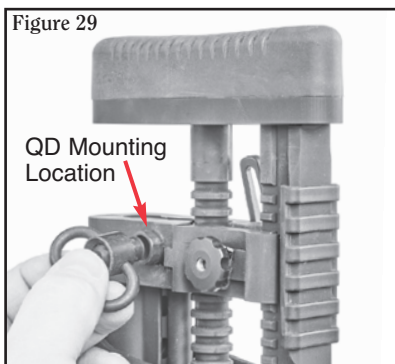

Reversing Side QD Attachment Point:

The QD attachment on the side of the adjustable stock can be relocated to the opposite side to accommodate alternate sling locations. To relocate this QD mounting location:

1. Loosen and remove the QD swivel cup using a 12mm wrench (see Figure 33).
2. Using a 1/8" Allen wrench, remove the screw on the opposite side (see Figure 34).
3. Switch the screw to the reverse side and tighten using a 1/8" Allen wrench. **NOTE:** The screw must be tightened to the center rod prior to installing the QD swivel cup.
4. Reinstall the QD swivel cup using a 12mm wrench.

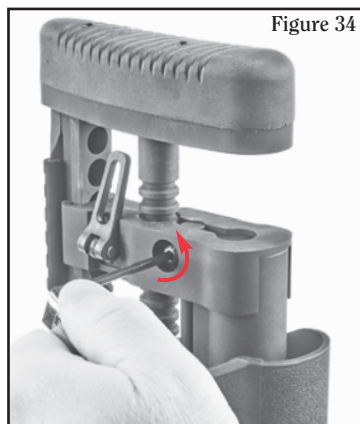
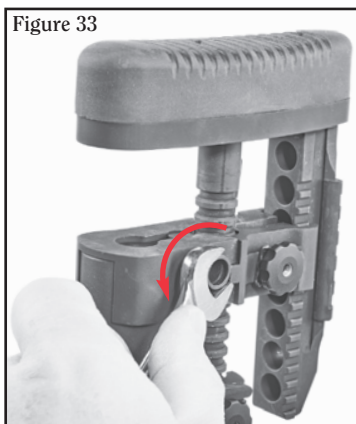

QD Mount Attachment:

Your **RUGER PRECISION RIFLE™** also comes with a QD mount that can be installed on the handguard using the Key Mod mounting holes. (The mount is located in the accessory pack included in your rifle box.) To attach the QD mount, first loosen the screw with a 3/32" Allen wrench. Now slide the mount into the Key Mod slot of your choice (see Figure 35). The screw on the QD mount should be inserted first and nearest to the muzzle (with the mount nearest the stock). Finally tighten the screw on the QD mount with the 3/32" Allen wrench (see Figure 36).

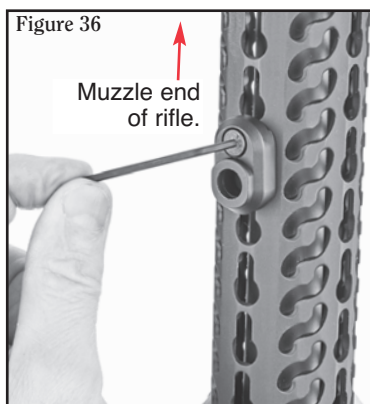
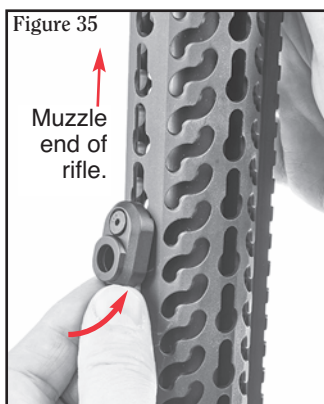

Picatinny Rail Attachment:

Your **RUGER PRECISION RIFLE™** also includes a section of Picatinny Rail (Mil Spec 1913) that can be installed on the handguard using the Key Mod system for mounting lights, lasers or other devices that utilize a Picatinny Rail mount. The Picatinny Rail is located in the accessory pack included in your rifle box. The accessory pack also includes a conventional sling stud that can be installed on the Picatinny Rail and utilized as a mounting point for a bipod.

To install the sling stud on the Picatinny Rail, first remove the center screw using a 3/32" Allen wrench (see Figure 37). Be careful to hold the nut in place when removing the screw. (If you drop the nut, you must take care to reinstall it in the correct orientation (see Figure 38). Carefully thread the sling stud into the nut a few turns (see Figure 39).

Figure 37

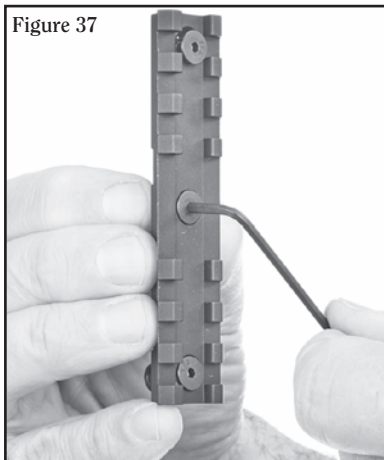

Figure 38

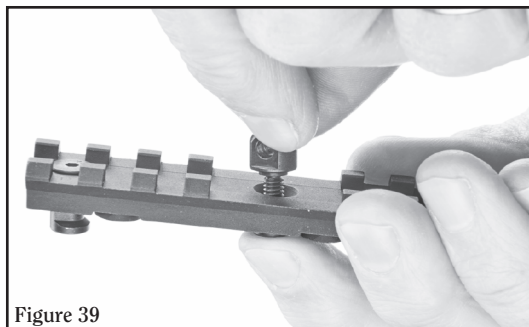
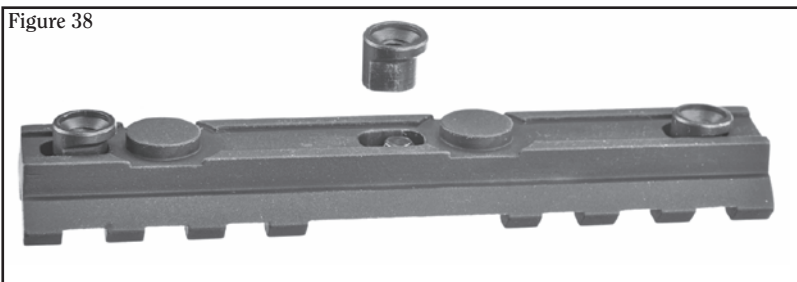
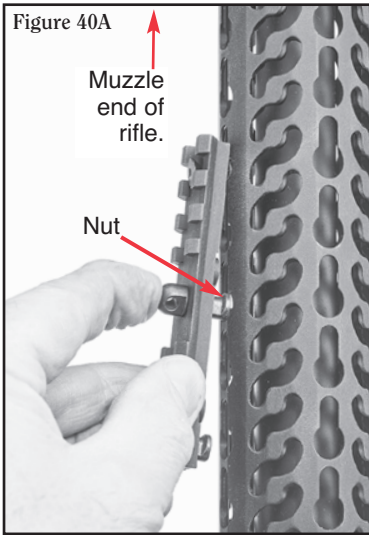
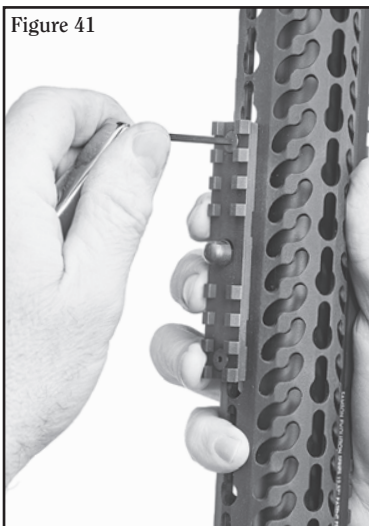



Figure 39

To mount the Picatinny Rail, loosen the screws using a 3/32" Allen wrench (provided), and loosen the sling stud by hand (if installed). Next, slide the nut (located on the back of the rail) into the Key Mod slots on the handguard (see Figures 40A & 40B).



Tighten the screws using the 3/16" Allen wrench (see Figure 41). Tighten and align the sling swivel so that it is perpendicular to the barrel (see Figure 42).



 WARNING – DISASSEMBLY	
	Always unload a firearm before cleaning, lubrication, disassembly or assembly.
UNLOAD BEFORE PERFORMING MAINTENANCE	

DISASSEMBLY

(Rifle Must Be Unloaded Prior to Disassembly)

This section will cover disassembly of the **RUGER PRECISION RIFLE™**. It will only be necessary to disassemble up to the step required for the particular area you will be servicing. Disassembly beyond what is described in this section is not recommended and may result in a non-functioning firearm.

An on-line video demonstrating the disassembly and reassembly of the **RUGER PRECISION RIFLE™** can be viewed by going to www.ruger.com/precisionrifle.

It is preferable to carry out these procedures on a workbench or table which has a covered top. A piece of shallow nap rug or an old, coarse blanket is an ideal covering. Such a covering not only reduces the chances of the rifle slipping and being scratched, but also it serves to trap pins, plungers and springs that may otherwise get lost. It is advisable to have a container – such as a shoebox – in which each part can be placed as it is removed from the gun.

Before attempting to disassemble the rifle for the first time, study the parts drawing and parts list to become familiar with the relative position, appearance and name of each part. Carry out the disassembly slowly and carefully note the position of the part in the gun before starting to remove it. If a part is under spring tension, remove it cautiously and anticipate the direction the spring and plunger are most likely to “jump.”

WARNING: If a spring or plunger becomes lost, do not use a substitute. Springs of correct tension are vital to the safe and reliable performance of firearms. Before starting disassembly, it is recommended to remove any unnecessary accessories that may interfere with the handling of the firearm.

To Disassemble Your Ruger Precision Rifle™:

1. Keep the muzzle pointed in a safe direction at all times and keep your fingers outside the trigger guard.
2. Move the safety selector switch to the “SAFE” position if the firing pin is cocked.
3. Remove the magazine. **REMEMBER** that even though the magazine has been removed, a cartridge remaining in the chamber can still be fired!
4. Raise the bolt handle and draw the bolt fully to the rear, extracting and ejecting any cartridge in the chamber.
5. If the safety selector switch is in the “FIRE” position, move it to the “SAFE” position (see Figure 4, p. 11).
6. Always visually double check the chamber to be certain it is empty. At this point no magazine should be in the rifle.
7. To remove the bolt: Close the bolt and push the folding stock release button (see Figure 43).

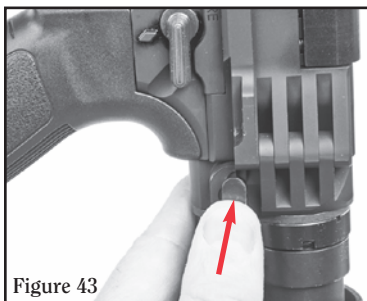

Figure 43

Fold the stock to the left (see Figure 44). Rotate the tab end of the folding stock button clockwise $\frac{1}{4}$ turn and lock the stock in the folded position (see Figure 13, p. 24). Remove the bolt by lifting the bolt handle and retracting the bolt while at the same time pressing on the rear of the bolt stop located on the left side of the receiver (see Figure 45). This is as far as you need to dismantle the rifle for a routine cleaning.

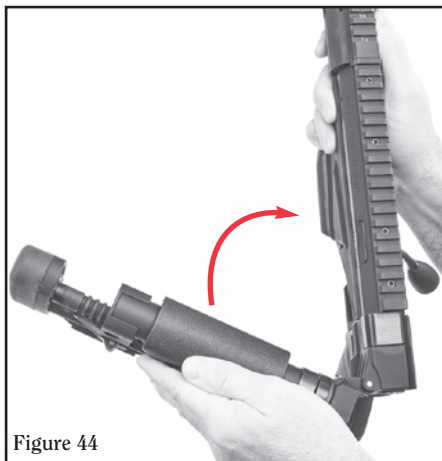

Figure 44

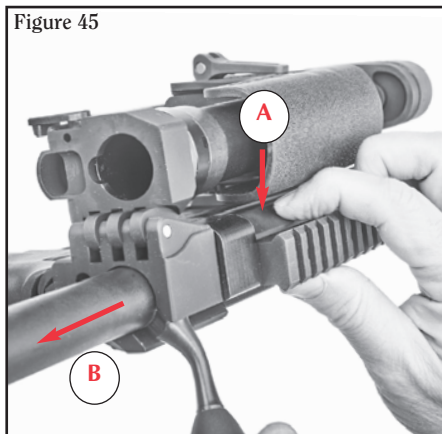

Figure 45

Disassembly of Bolt for Cleaning:

If the rifle is used extensively, it may occasionally be desirable to lubricate the cocking cams. Note that this is not something that should be necessary under typical usage conditions.

To clean the bolt: **NOTE:** The cocking piece will only rotate fully if turned clockwise, relative to the bolt body (when viewed from the rear of the bolt – see Figure 7, p. 13 for proper position). Do not rotate the cocking piece beyond the positions shown in the instructions. If the cocking piece is turned too far, it will “fall down” to the bottom of the cocking cams and will take significant effort, and possibly the use of hand tools or a gripping aid, to return the cocking piece to the correct cam notches. Because there are dual cocking cams, you may need to rotate the cocking piece through both cams in order to return the cocking piece to its proper position.

- a. Start with the bolt in the position shown in Figure 46. You can see the lobe on the cocking piece is at rest inside the notch on the cam.

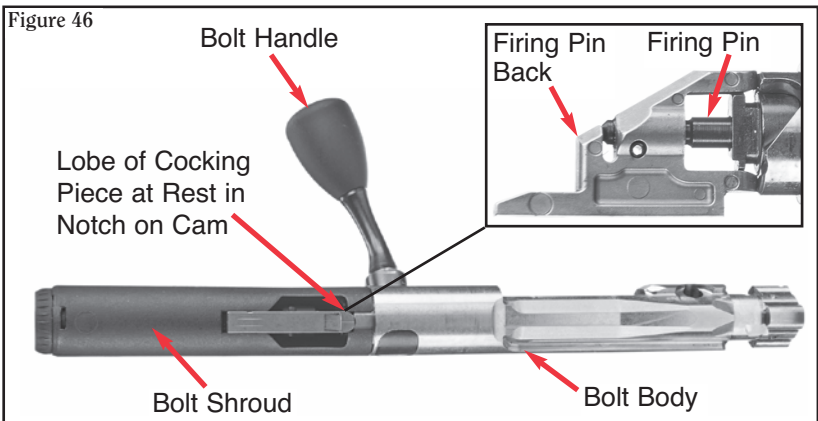

- b. Grasp the outside of the bolt shroud and cocking piece, and rotate clockwise (when looking from the rear of the bolt) approximately 30° as shown so the cocking piece lobe is aligned with the center of the bolt handle base. (See Figure 47A & B.)
- c. Pull the bolt shroud rearward and off. (See Figure 47C.) This is as far as you need to dismantle the rifle to lubricate the cocking cams.

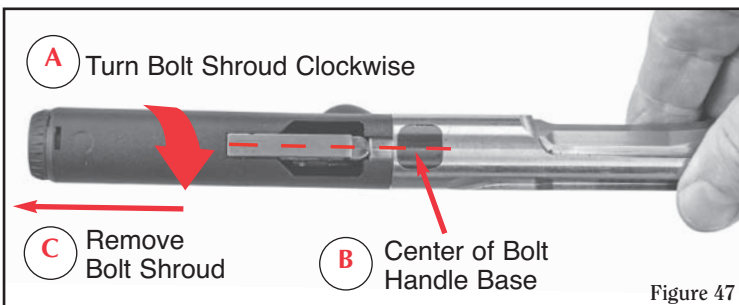

- d. **To lubricate cocking cams:** A grease-type gun lubricant is recommended. Grease cam surfaces and the firing pin shaft as shown in Figure 48. Note further disassembly of the bolt is not required for lubrication. Some parts are under spring tension and may dislodge abruptly if removal is attempted. Grease may also be lightly applied to the lug surface of the bolt as shown in Figure 49.

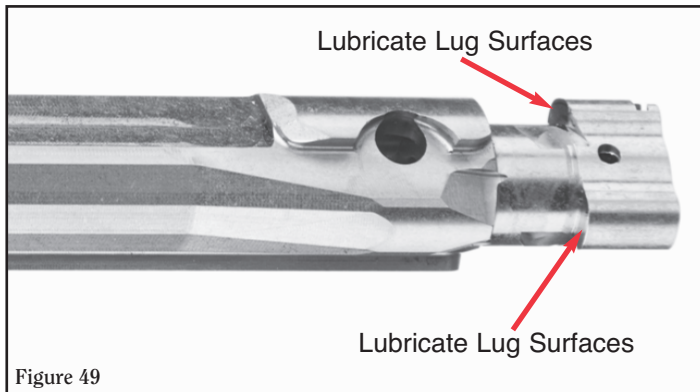
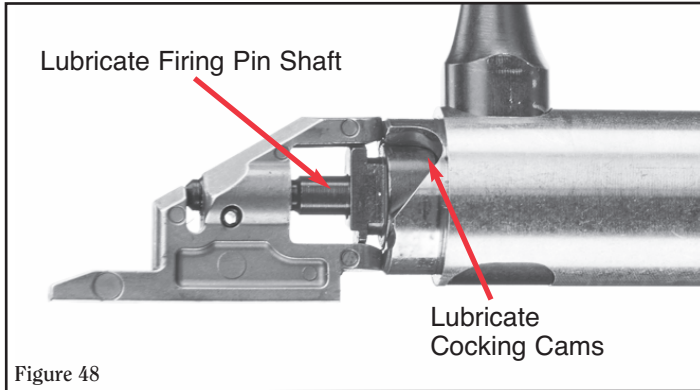

LOWER RECEIVER DISASSEMBLY

NOTE: The following steps should only be performed if inspection and/or cleaning of the lower receiver are required. It also will be necessary to perform these steps to reverse the safety selector switch (see page 39). Otherwise, always leave the lower receiver assembled.

1. **CHECK TO BE CERTAIN THAT THE CHAMBER AND MAGAZINE ARE EMPTY.** Remove the magazine.
2. Using a 3/16" Allen wrench, remove the cap screw at the bottom of the upper receiver. (See Figure 50.)
3. Unfold the stock, and using a 3/16" Allen wrench remove the cap screw at the front of the lower receiver as shown in Figure 51. **NOTE: Only remove the cap screws as identified above; no other cap screws should be removed or loosened.**

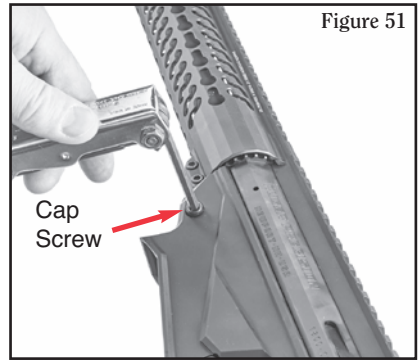
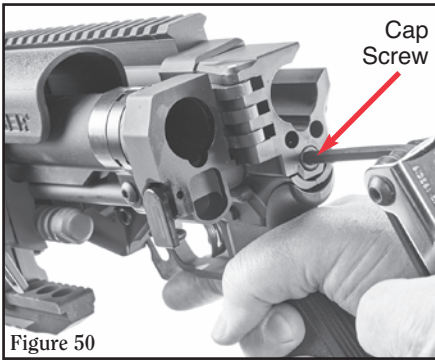

4. Rotate the rifle so that the magazine well opening is facing upwards.
5. Verify that the safety selector switch is in the "SAFE" position (see Figure 52) and lift upwards on the lower receiver (see Figure 53). **Note: If the safety selector switch is not in the "SAFE" position, the lower receiver cannot be removed.**

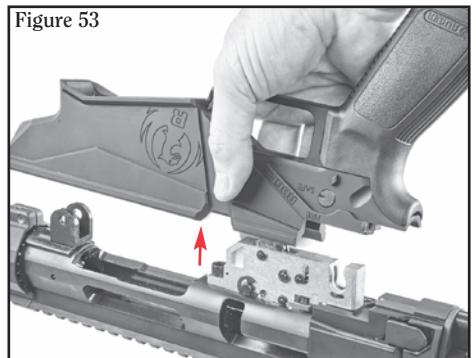

6. This is as far as you need to dismantle the rifle to clean the lower receiver and inspect the internals.

REVERSING THE SAFETY SELECTOR SWITCH

Now that the lower receiver is separated from the rifle, you can remove and reverse the safety selector switch, if desired. First, remove the safety selector switch by pulling it out from the indicator side (see Figure 54). Next, insert the safety selector switch into the other side of the lower receiver until it bridges across both holes (see Figure 55).

NOTE: There are no detent pins or springs in the system; the fire control housing retains the safety selector switch in the rifle. Take care to keep the safety selector switch in place during reassembly.

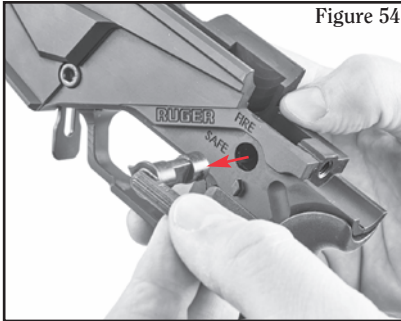

Figure 54

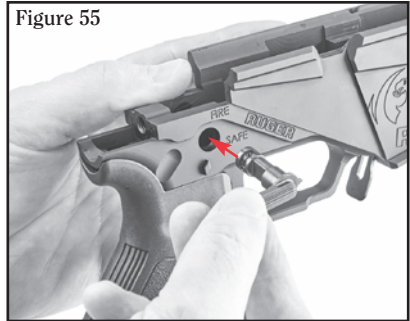

Figure 55

TRIGGER GROUP

Over time and with extensive use, it will become necessary to remove and clean the trigger group. It is recommended that you clean the trigger group approximately every 1,000 rounds. An increase in trigger pull weight (without adjustment) is an indicator that the trigger group may require cleaning.

The following steps should be performed if inspection and/or cleaning of the trigger group is required. Otherwise always leave the trigger group assembled:

1. Using a 3/16" Allen wrench remove the bolt at the front of the trigger assembly. (See Figure 56.)
2. Release the cocking guide spring by depressing the pin and allowing it to move into the long portion of the "J" shaped slot. (See Figure 57.)

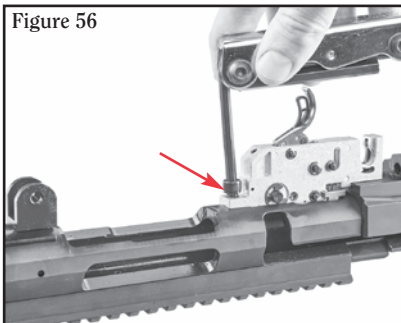

Figure 56

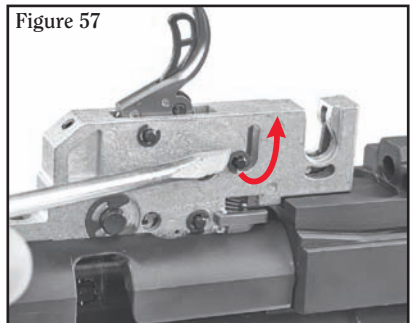

Figure 57

3. The cocking piece guide holds the trigger assembly forward and in place. Using a non-marring tool, depress the cocking piece guide through the bolt opening inside the receiver. (See Figure 58.) While holding the cocking piece guide down, slide the trigger assembly rearward towards the butt stock and out of the rifle (see Figure 58).
4. The trigger group should now be free from the receiver (see Figure 59). This is as far as you need to dismantle the rifle to clean the trigger group and inspect the internals. **Note: Further disassembly of the trigger group is not required for cleaning, some parts are under spring tension and may dislodge abruptly if removal is attempted.**

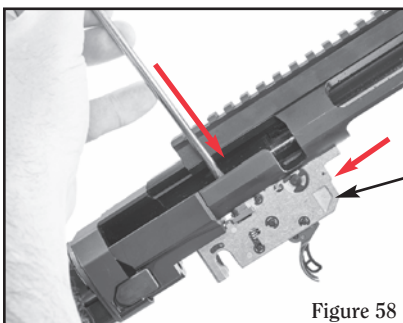
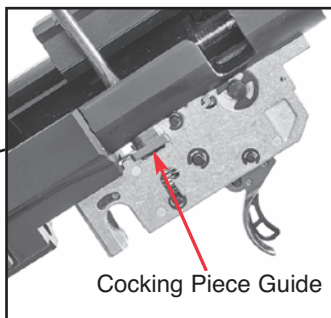

Figure 58



Cocking Piece Guide

HOW TO CLEAN THE TRIGGER GROUP

To clean your trigger group:

1. Materials recommended: non-chlorinated parts cleaner, cotton swab or other soft pointed cleaning tool, an oil-type gun lubricant, and a synthetic grease-type lubricant such as Slip 2000® EWG or equivalent (see Figure 59A).
2. With the trigger group removed from the rifle, spray the inside of the trigger group and surfaces as indicated in Figure 59.
3. Using a cotton swab, wipe down all visible surfaces as shown in Figure 59. Wipe away any debris that can be seen in and around the housing.

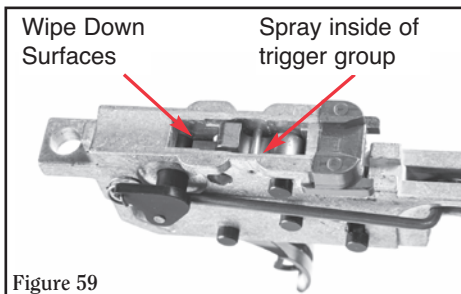

Figure 59



Figure 59A

4. Apply a drop of an oil-type gun lubricant to the axle shafts of the trigger group as shown in Figure 60. Allow the oil to run down the shaft into the assembly.
5. Using the Slip 2000® EWG syringe, apply grease to the trigger and sear (see Figure 60A). Insert grease where the sear meets the top of the trigger (see Figure 60B), until a 1/8" bead forms between the parts. Note the grease will spread along the surfaces and be visible through the inspection ports as shown in Figure 60C.
6. Apply a small bead of grease to the opposite side of the sear as shown in Figure 60D.

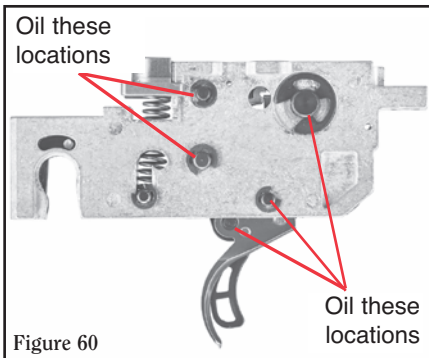

Figure 60

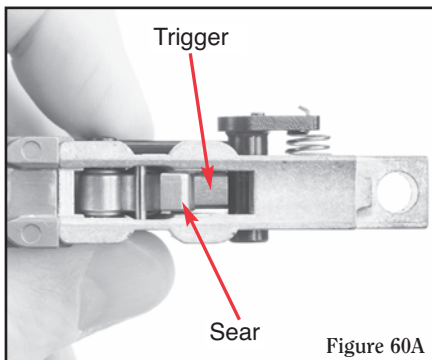

Figure 60A

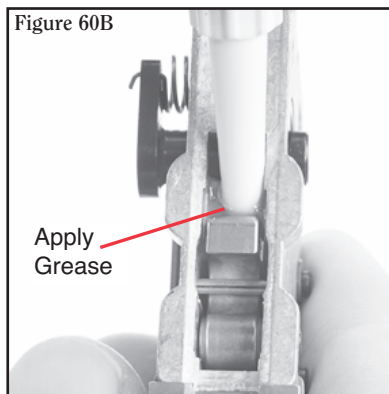

Figure 60B

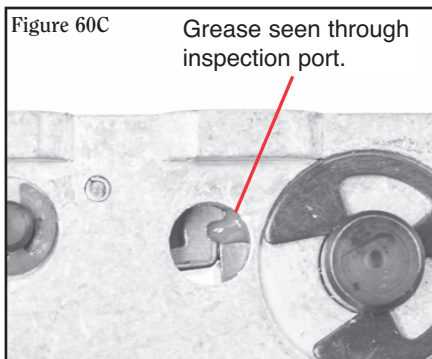

Figure 60C

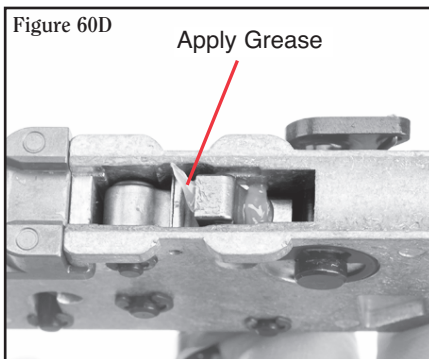

Figure 60D

CARE AND CLEANING

BEFORE CLEANING, BE CERTAIN THE RIFLE AND ITS MAGAZINE CONTAIN NO CARTRIDGES.

An on-line video demonstrating the cleaning of the **RUGER PRECISION RIFLE™** can be viewed by going to www.ruger.com/precisionrifle.

A firearm must be free of rust, dirt, grease and firing residues to function safely and reliably. Periodic maintenance, which includes inspection of components to determine if they are in proper working order, is absolutely essential. Firing deposits particles of bullet, lubricant and powder in the bore, chamber, bolt, receiver, magazine and other parts of the rifle. There is no fixed rule as to how frequently the cleaning should be carried out, but the alert gun owner soon learns that any firearm functions most reliably and accurately when it is free of accumulations of grease and other firing residues.

Basic cleaning equipment includes: A correct size cleaning rod equipped with bore brushes (fiber and brass) and a tip in which a cloth patch can be inserted, patches, powder solvent, lubricant, small lint-free cloths and a toothbrush. Use correct size patches and brushes. Larger sizes will bind in the bore and can be very difficult to remove! Insert rod from the chamber end of the barrel and push firmly so the patch or brush emerges from the muzzle. Do not reverse the rod when a brush or patch is being used before the brush or patch exits the muzzle – it may bind. Do not use patches or brushes dripping with solvent or oil. Use rod and brushes with care so as not to damage the gun.

1. For routine cleaning it is necessary only to remove the bolt and magazine.
2. Push-pull a properly sized, solvent-wetted patch through the bore several times. Next, using a solvent-wetted brush, run it the full length of the bore as many times as is necessary to completely remove all foreign matter from the bore and chamber. Dry the bore with clean patches and examine it. If the bore remains fouled, repeat the brushing. Complete the cleaning by dry-patch wiping of bore and chamber.
3. Use a clean, solvent-wetted patch to remove firing residue and dirt from all “reachable” surfaces inside the receiver. Use the solvent-wetted toothbrush to dislodge caked dirt from all parts of the bolt assembly and from surfaces inside the receiver that cannot be reached with a patch. Use cleaning patches or the cloth to remove the solvent.
4. If lifting the bolt handle becomes difficult or requires more force than usual, remove the end cap (see Disassembly of Bolt for Cleaning, p. 36 & 37) and clean and lubricate the bolt cocking cam surfaces.
5. Wipe all surfaces – internal and external – with a very light coat of oil. Oil and similar preparations “collect” dirt particles which can interfere with reliable functioning of the rifle. Therefore, use these preparations very sparingly. A drop of oil applied to the bolt assembly components, the pivot points of the trigger mechanism, the safety, the bolt stop, and the magazine latch, will work into all the parts that need lubrication.
6. Reassemble the rifle and carefully wipe off all excess solvent, lubricating and preservative preparations from the rifle.
7. If the rifle is to be stored for an extended period, clean the rifle thoroughly. Disassemble to the extent described elsewhere in this manual, taking care to put pins and similar easily mislaid and “rolling” components in a tray. Rewipe all surfaces with preservative oil. Reassemble and store properly.



WARNING – LUBRICATION



Firing a rifle with oil, grease, or any other material even partially obstructing the bore may result in damage to the rifle and serious injury to the shooter and those nearby. Do not spray or apply lubricants directly on ammunition. If the powder charge of a cartridge is affected by the lubricant, it may not be ignited, but the energy from the primer may be sufficient to push the bullet into the bore where it may become lodged. Firing a subsequent bullet onto the obstructed bore may damage the rifle and cause serious injury or death to the shooter and those nearby. Use lubricants properly. You are responsible for the proper care and maintenance of your firearm.

**IMPROPER LUBRICATION
DESTROYS GUNS**

REASSEMBLY

1. **Trigger Group:** With the upper receiver standing upside down on a bench, insert the trigger group into the receiver, and slide it away from the butt stock. (See Figure 61.)
 - a. Grasp the cocking piece guide and maneuver it into the mating feature, making sure that it seats out fully against the receiver (see Figure 62A).
 - b. Compress the cocking piece guide spring by moving the pin into the short portion of the “J” shaped slot. (See Figure 62B.)
 - c. Using a 3/16” Allen wrench, tighten the front trigger assembly screw. (See Figure 56, p. 39.)

Figure 61

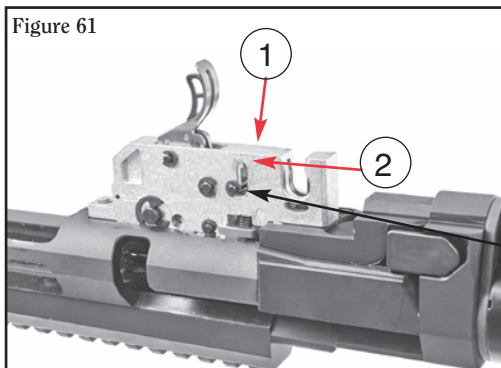
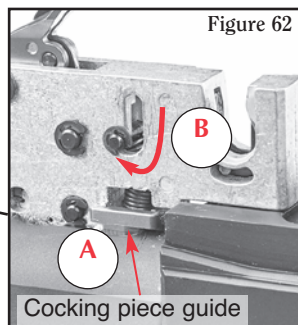

Figure 62



2. **Lower Receiver:** Insert the safety selector switch into the lower receiver, and with the safety selector switch in the “SAFE” position, install the lower receiver back onto the rifle. Fold the stock and install the cap screw. Then unfold the stock and install the cap screw (sequence is important to properly seat components). Follow Figures 50 through 53, p. 38, in reverse order.
3. Test the function of the safety.

4. Bolt Reassembly:

- a. Install the bolt shroud by sliding it over the end of the firing pin. Rotate the bolt shroud 30 degrees counterclockwise (see Figure 62) and the firing pin back will lock into the bolt in the at rest position (see Figure 63).
- b. Replace the bolt in the rifle and **visually double check the chamber to be certain it is empty. At this point no magazine should be in the rifle.**

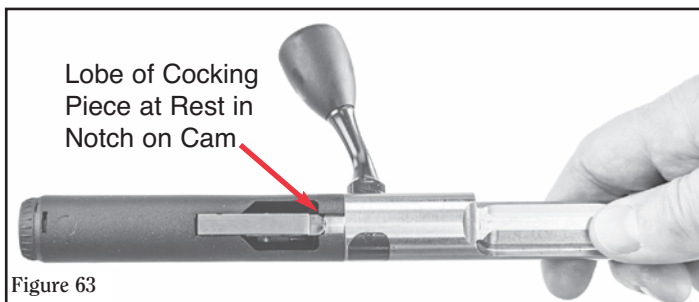
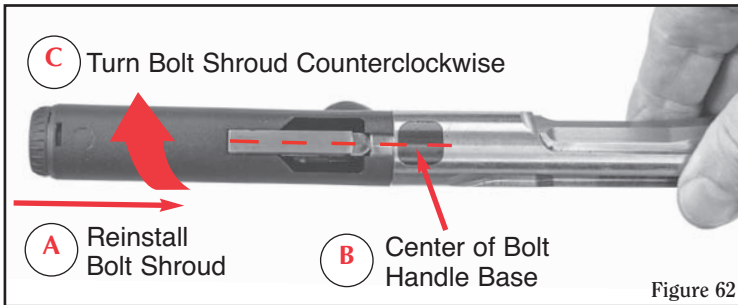

While practicing safe firearm handling skills, test the movement and function of the safety from the safe position to the fire position. By dry firing the rifle, ensure that the safety is preventing the firing pin from advancing. If the above procedures do not result in a safe operating firearm, do not use the gun. The rifle can be returned directly to our Newport, New Hampshire Customer Service Department for repair. See the “Service and Parts Policy” section, page 46, of this manual for packing and shipping information.



STORAGE

GUNS SHOULD NOT BE STORED LOADED!

USE THE LOCKING DEVICE SUPPLIED WITH THE RIFLE FOR STORAGE.

(See Page 7)

Do not store the rifle in a leather case or scabbard. Leather attracts moisture, even though it may appear to be dry.

 WARNING – STORAGE	
	<ul style="list-style-type: none">• Never place or store any firearm in such a manner that it may be dislodged. Firearms should always be stored securely and unloaded, away from children and careless adults.• Use the locking device supplied with the rifle for storage. The use of a locking device or safety lock is only one aspect of responsible firearms storage.• For increased safety, firearms should be stored unloaded in a location that is both separate from their ammunition and inaccessible to children and any other unauthorized person.
STORE SECURELY & UNLOADED	

SERVICE AND PARTS POLICY

If you have any question with regard to the performance of your **RUGER PRECISION RIFLE™** please write or call (603-865-2442) our Customer Service Department in Newport, New Hampshire 03773, fully describing all circumstances and conditions involved. If you should return your rifle to the factory for repair, or order parts for it, please comply with the following suggestions for prompt service:



WARNING: BEFORE SHIPPING ANY FIREARM, BE ABSOLUTELY CERTAIN THAT THE FIREARM AND ITS MAGAZINE ARE UNLOADED. DO NOT SHIP CARTRIDGES WITH A FIREARM.

SHIPPING FIREARMS FOR REPAIR

RUGER PRECISION RIFLES™ returned to the factory for repair should be sent to: Sturm, Ruger & Company, Inc., Customer Service Department, 411 Sunapee St., Newport, New Hampshire 03773. The complete rifle should be shipped. **NOTE: You must obtain a Repair Authorization Number before returning your firearm.** An authorization number can be obtained by contacting Customer Service online at www.ruger.com or calling the Customer Service Dept. at 603-865-2442. Guns should be sent prepaid. We will not accept collect shipments.

The Federal Gun Control Act, as well as the laws of most states and localities, do not prohibit an individual (who is not otherwise barred from purchasing or possessing a firearm) from shipping a firearm directly to the manufacturer for repair. However, before you ship your rifle to us, be certain that your state or locality does not have a law or regulation which will prohibit you from receiving the rifle from us after it has been repaired. If such receiving is prohibited, then please have a Federally Licensed Firearms Dealer ship the gun to us. If your rifle is sent to us by a dealer, it will be returned to that dealer after being repaired.

DO NOT SEND GUN BOXES OR LITERATURE THAT YOU CONSIDER TO BE COLLECTOR'S ITEMS – THESE ARE INVARIABLY DAMAGED OR DESTROYED IN SHIPMENT. Please do not include rifle case, sling, telescopic sights or custom accessories with a firearm being shipped to the factory for service. Rifles and shotguns may be shipped via U.S. Mail. Always insure your shipment.

Enclose a letter which includes your name, address, telephone number, serial number, model of the firearm, and your repair authorization number. Describe in detail the trouble you have experienced with your firearm, or the work you wish to have done. Merely stating that the firearm “needs repair” is inadequate information.

All work performed is subject to a minimum labor charge and charges for shipping and handling. Most models can be reblued, but custom gunsmithing service or nonstandard alterations are **NOT AVAILABLE** from Ruger Customer Service Departments. Please contact the Customer Service Department for pricing information.

WARNING – PARTS PURCHASERS	
	
	<ul style="list-style-type: none"> • It is the purchaser's responsibility to be absolutely certain that any parts ordered from the factory are correctly fitted and installed. • Firearms are complicated mechanisms and IMPROPER FITTING OF PARTS MAY RESULT IN A DANGEROUS MALFUNCTION, DAMAGE TO THE FIREARM, AND SERIOUS INJURY TO THE SHOOTER AND OTHER PERSONS. • The purchaser and installer of parts must accept full responsibility for the correct adjustment and functioning of the firearm after such installation.
PARTS MUST FIT CORRECTLY	

ORDERING PARTS

Please contact the New Hampshire Customer Service Department for parts availability and current prices. All parts orders for the **RUGER PRECISION RIFLE™** should be sent to: Sturm, Ruger & Co., Inc., Customer Service Department, 411 Sunapee Street, Newport, New Hampshire 03773, 603-865-2442. We cannot comply with open account or C.O.D. requests. Payment in full via credit card (Visa or MasterCard only), money order or certified bank check (no personal checks or cash, please) is required before any service will be performed. Please provide your credit card number, your name as it appears on the credit card, the expiration date, and the 3-digit security code. All parts orders are subject to a minimum charge and charges for shipping and handling. Order parts by Part Name and Part Number and include the entire serial number of the firearm for which the parts are being ordered. There is a minimum labor charge plus a shipping and handling charge if the parts are factory fitted. All factory fitted parts are fit on an exchange basis only. We will not return the replaced parts. Please contact the Customer Service Department for pricing information.

Barrels, and a number of other component parts must be fitted at the factory. Company policy is to proof-test and/or function fire all barrels after fitting to the receivers in which they are to be used. This procedure ensures maximum protection to our customers. The special proof-test ammunition used in this testing is sold only to bonafide firearms manufacturers and is not available to gun shops, gunsmiths or individuals.

Because the receiver of the **RUGER PRECISION RIFLE™** is a serial numbered component, it is defined as a "firearm" by Federal law and is not sold as a separate component.

*Parts designated by an asterisk must be factory fitted. These parts are fitted on an exchange basis only. We will not return the replaced parts. We will not return any part that is broken, malfunctioning, badly worn or has been modified. See "Warning – Parts Purchasers," above.

	<p>WARNING: A gun containing broken, malfunctioning or badly worn parts should not be fired.</p>
---	---

RUGER PRECISION RIFLE™

PARTS LIST

Design, prices and specifications subject to change without notice.

(See Exploded Views on Pages 51 -54)

Key	Part Name	Part No.	Model
* 1	Bolt / Firing Pin Assembly – Complete Includes Key Nos. 2 - 18 (See Exploded View p. 51)		All Models
2	Bolt Shroud Assembly, Short w/Cap & 5/64" Hex Wrench	DBA21702	All Models
3	Firing Pin Back	DBA01802	All Models
4	Firing Pin Spring Stop	DBA03501	All Models
5	Firing Pin, Short Action	DBA01102	All Models
6	Firing Pin Spring	DBA01201	All Models
7	Bolt Knob	DBA00088	All Models
8	Ejector/Firing Pin Back Pin	DBA01900	All Models
9	Ejector Spring	DBA00901	All Models
10	Ejector Plunger	DBA00802	All Models
11	Extractor	DBA01401	All Models
12	Extractor Ball	DBA08601	All Models
13	Extractor Spring	DBA08701	All Models
* 14	Bolt Body, Short Action	DBA01008	All Models
15	Bolt Handle	DBA01603	All Models
† 16	Receiver	TAC00100	All Models
* 17	Barrel Nut	DBA00303	All Models
* 18	Barrel	0TAC8001	18001
	Barrel	0TAC8002	18005
	Barrel	0TAC8003	18010
* 19	Trigger Assembly – Complete Includes Key Nos. 20 - 40 (See Exploded View p. 52)		All Models
20	Safety Connector	DBA03704	All Models
21	Cocking Piece Guide Spring	DBA02415	All Models
22	Cocking Piece Guide	DBA01320	All Models
23	Sear Spring	DBA02402	All Models
* 24	Sear	DBA02301	All Models
* 25	Safety Link	DBA03703	All Models
26	Sear Stop Pin	DBA05601	All Models
* 27	Trigger block Pin	DBA04502-135	All Models
28	Trigger-Sear Pin, 3 Req'd	DBA02101	All Models
* 29	Safety Shaft	DBA03603	All Models
* 30	Safety Spring	DBA05402	All Models
* 31	Trigger Housing	DBA01302	All Models
32	Trigger-Sear Pin E-Clip, 3 Req'd	DBA04201	All Models
33	Trigger Block Pin E-Clip	DBA04601	All Models
34	Safety Shaft E-Clip	DBA05501	All Models

* Parts so marked must be factory fitted.

† The receiver is a serial-numbered part and is not offered for sale.

Key	Part Name	Part No.	Model
* 35	Trigger Release	DBA05701	All Models
36	Trigger Release Spring	DBA04901	All Models
* 37	Trigger	DBA02002	All Models
38	Trigger Release Pin	DBA05901	All Models
39	Trigger Pull Adjustment Spring	DBA02503	All Models
40	Trigger Adjustment Screw	DBA08103	All Models
41	Stock Assembly – Complete		
	Includes Key Nos. 42 - 68 (See Exploded View p. 53)		
42	Rail Cover	DBA13512	All Models
43	Butt Pad Screw, 2 Req'd	DBA08300	All Models
44	Recoil Pad	D06319	All Models
45	Recoil Pad Base Plate Screw, 2 Req'd	DBA00092	All Models
46	Recoil Pad Base Plate	DBA06301	All Models
47	Lower Picatinny Rail	DBA13506	All Models
48	Adjustment Rod	DBA13505	All Models
49	Rear Stock Frame	DBA15302	All Models
50	Cheek Rest	DBA15304	All Models
51	Stock Cam Spring, 3 Req'd	DBA13511	All Models
52	Stock Detent Washer, 4 Req'd	DBA00039	All Models
53	QD Swivel Cup	DBA00083	All Models
54	Cam Nut, 2 Req'd	DBA00079	All Models
55	Buffer Tube	NS00400	All Models
56	Stock Front Clamp	DBA15301	All Models
57	Stock Connector Rod	DBA15303	All Models
58	Acorn Nut	DBA00089	All Models
59	Castle Nut	NS00088	All Models
60	End Plate	NS00087	All Models
61	Stock Front Clamp Bottom	DBA15305	All Models
62	Stock Clamp Screw, 2 Req'd	DBA00084	All Models
63	Cheek Clamp, 2 Req'd	DBA13510	All Models
64	Stock Length Lock	DBA13507	All Models
65	Cam Lever, 2 Req'd	DBA13508	All Models
66	Cam Cross Pin, 2 Req'd	KDBA13509	All Models
67	Cam Rod Short	DBA00077	All Models
68	Cam Rod Long	DBA00078	All Models
69	Stock Mount Back	DBA13700	All Models
70	Stock Pivot Latch	DBA00034	All Models
71	Stock Pivot Latch Pin	KDBA01901	All Models
72	Latch Spring	KDBA14401	All Models
73	Stock Mount Bottom	DBA13701	All Models
74	Stock Hinge Pin washer, 2 Req'd	DBA05603	All Models
75	Stock Hinge Pin	DBA05600	All Models
76	Stock Mount Top	DBA13702	All Models
77	Scope Mount Screw, 4 Req'd	DBA06103	All Models
78	Stock Latch detent Washer	DBA00038	All Models

* Parts so marked must be factory fitted.

Key	Part Name	Part No.	Model
79	Stock Pivot Lock Button	DBA00038	All Models
80	Bolt Stop Spring	DBA05303	All Models
81	Bolt Stop	DBA05304	All Models
82	Bolt Stop Pin	DBA05302	All Models
83	Scope Base	DBA08810	All Models
84	Hinge Mounting Screw, 2 Req'd	DBA04804	All Models
85	Mounting Screw, 2 Req'd	DBA00081	All Models
86	Barrel Nut Lock	DBA01790	All Models
87	Handguard Nut Ring	DBA00310	All Models
88	Handguard Nut	DBA00302	All Models
89	12 1/4" Handguard w/ (2) Thermal Bushings	DBA16600	All Models
	15" Handguard w/ (2) Thermal Bushings	DBA16601	All Models
90	Muzzle Cap	DBA01345	All Models
91	Short Lower, Right	DBA13100	All Models
92	Short Lower, Left	DBA13101	All Models
93	Safety Selector	NS13800	All Models
94	Mounting Screw, 3 Req'd	DBA04801	All Models
95	Lower Lever Pin	KDBA03104	All Models
96	Side Catch Spring	DBA03106	All Models
97	Magazine Side Latch Pin	DBA05604	All Models
98	Magazine Latch Lever Spring	KDBA03202	All Models
99	Magazine Latch Lever	DBA03102	All Models
100	Magazine Latch Side Catch	DBA03103	All Models
101	Lower Front Mount	DBA00670	All Models
102	Grip Screw	NS00069	All Models
103	Grip Washer	MA13500	All Models
104	Pistol Grip	ND00075	All Models
105	Magazine	NS12711	All Models

RUGER PRECISION RIFLE™

BOLT / FIRING PIN ASSEMBLY

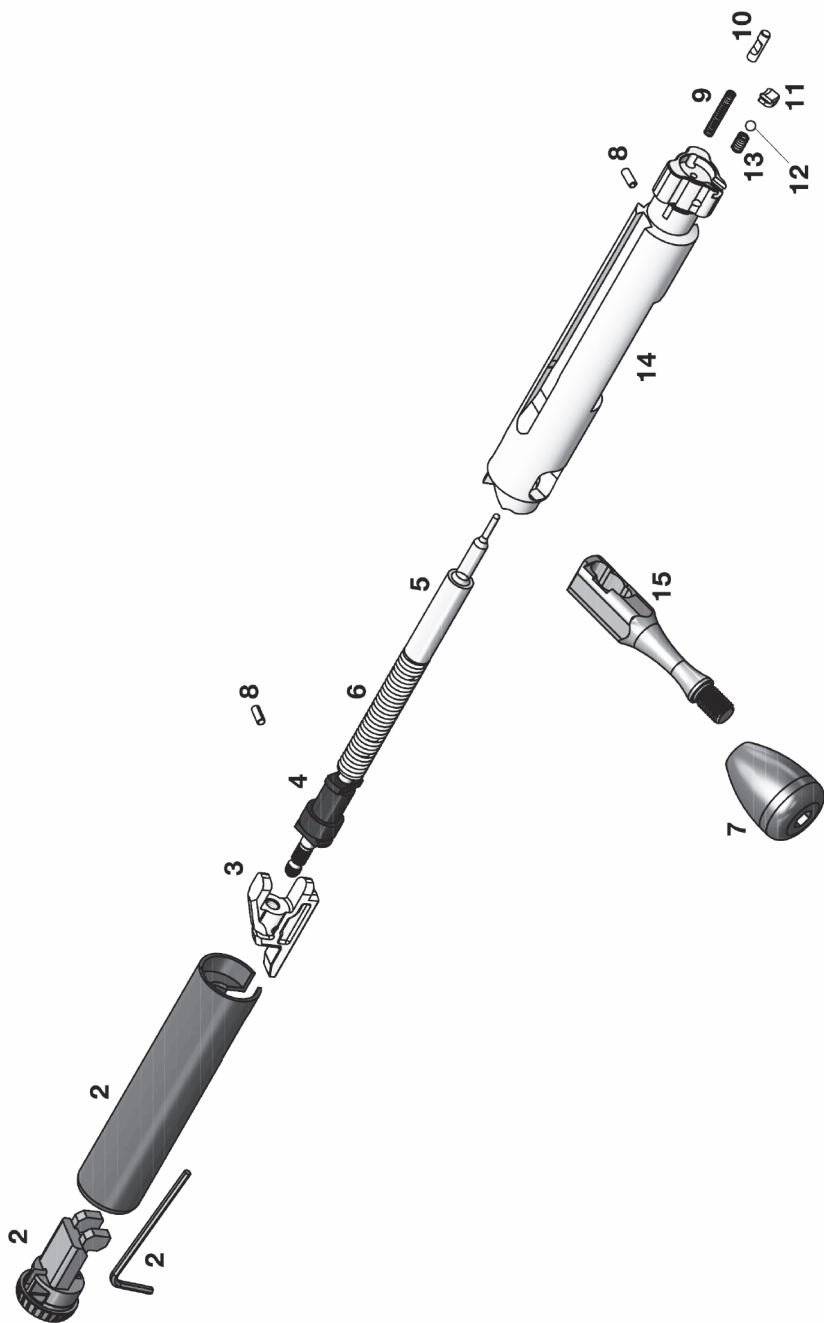

RUGER PRECISION RIFLE™

TRIGGER ASSEMBLY

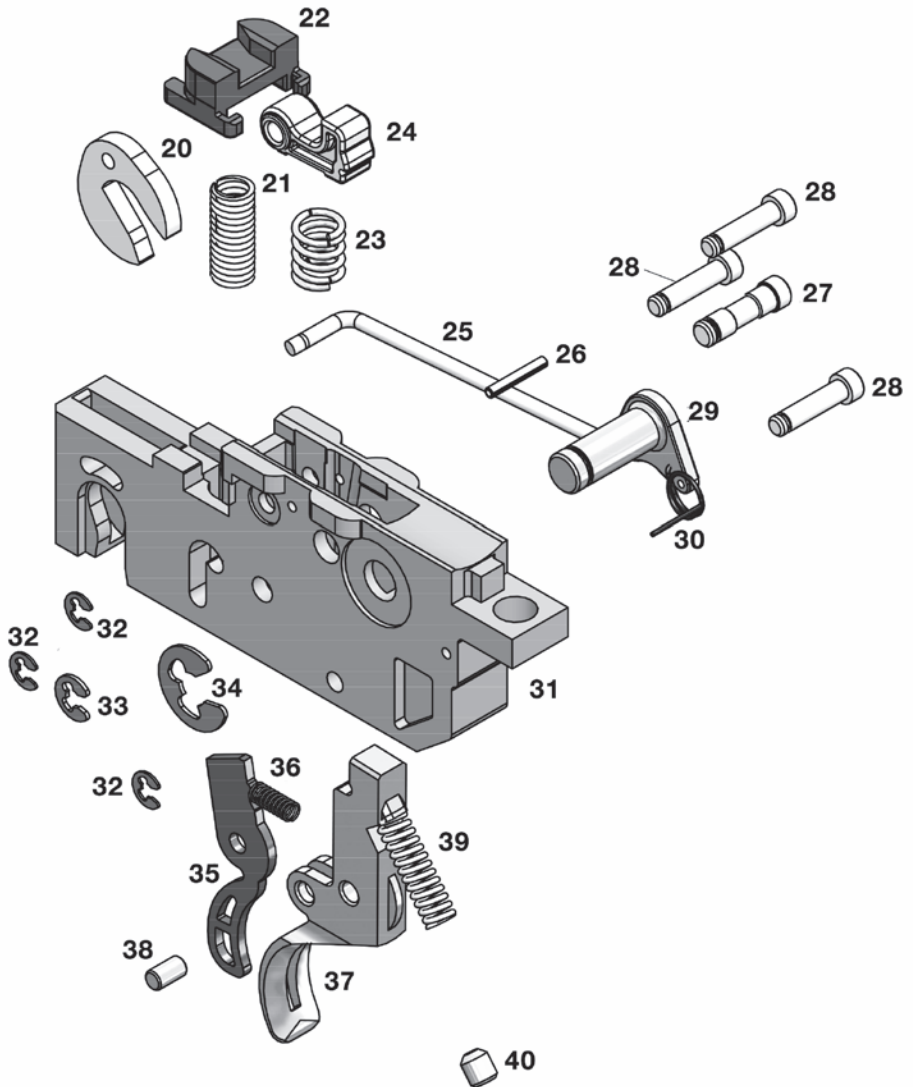

RUGER PRECISION RIFLE™

STOCK ASSEMBLY

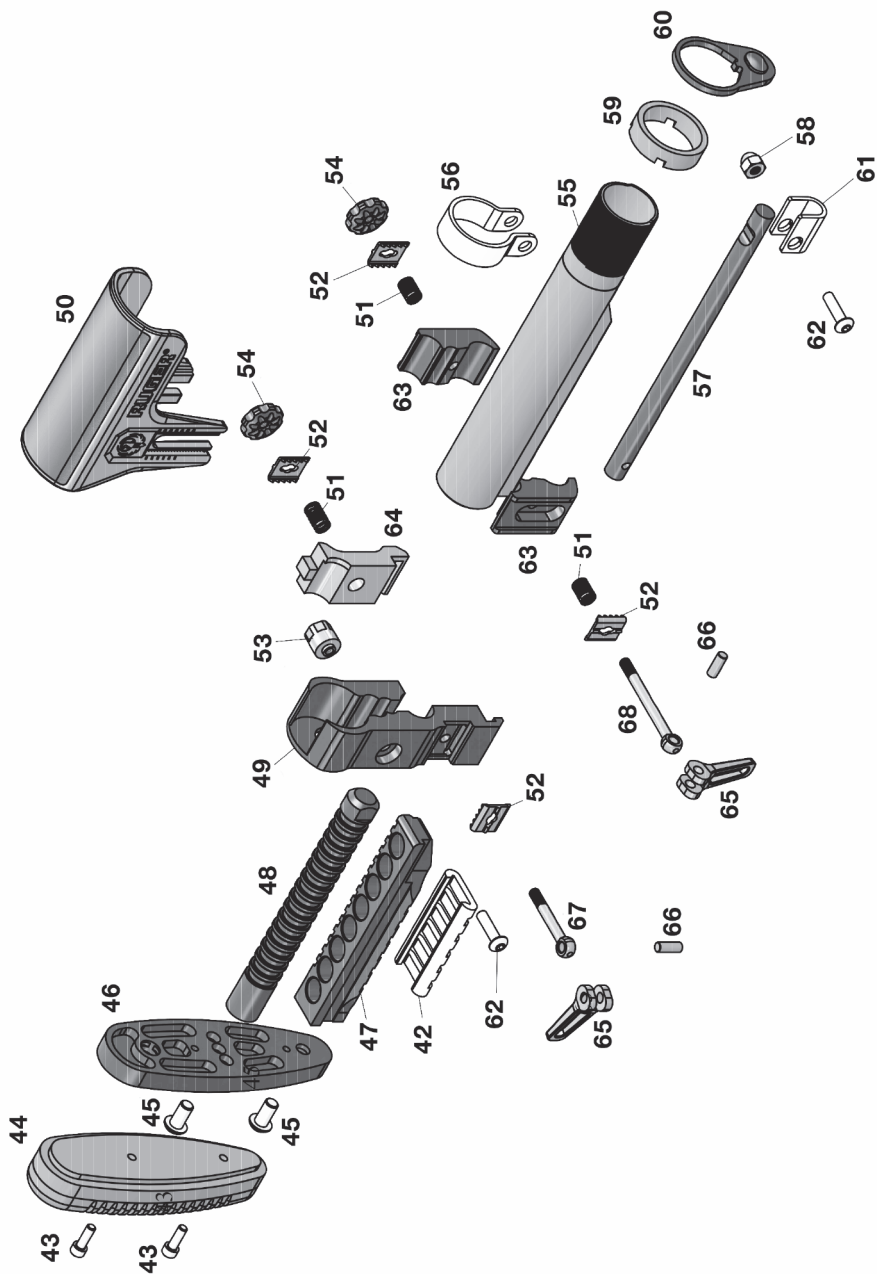

RUGER PRECISION RIFLE™

EXPLODED VIEW

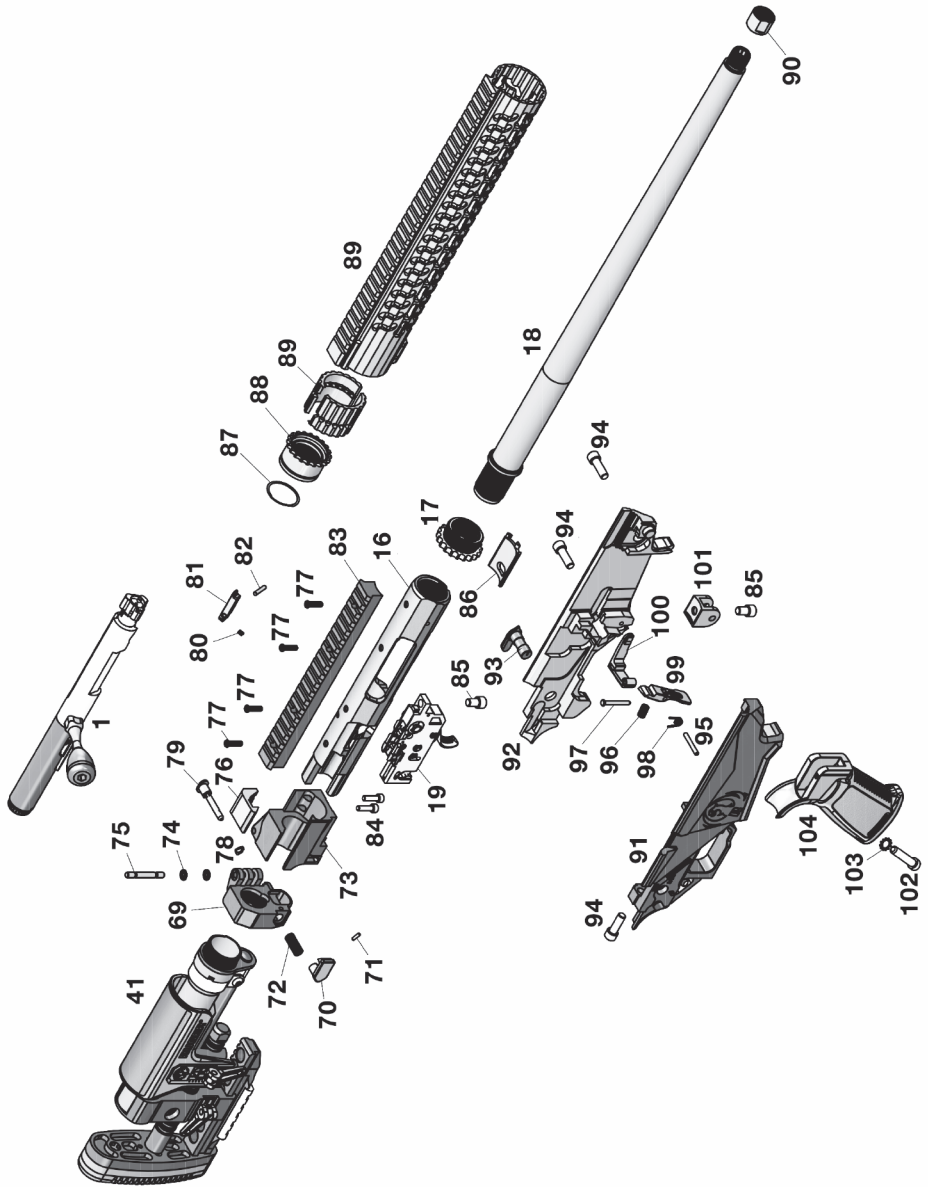

THE BASIC RULES OF SAFE FIREARMS HANDLING

We believe that Americans have a right to purchase and use firearms for lawful purposes. The private ownership of firearms in America is traditional, but that ownership imposes the responsibility on the gun owner to use his firearms in a way which will ensure his own safety and that of others. When firearms are used in a safe and responsible manner, they are a great source of pleasure and satisfaction, and represent a fundamental part of our personal liberty.

Firearms do not cause accidents! Firearms accidents are almost always found to have been the result of carelessness or ignorance on the part of the shooter of the basic rules of safe gun handling.

The following rules must be observed by gun users at all times. Safe gun handling is not just desirable, it is absolutely essential to your safety, the safety of others, and the continuation of gun ownership and sport shooting as we know it today.

1. LEARN THE MECHANICAL AND HANDLING CHARACTERISTICS OF THE FIREARM YOU ARE USING.

Not all firearms are the same. The method of carrying and handling firearms

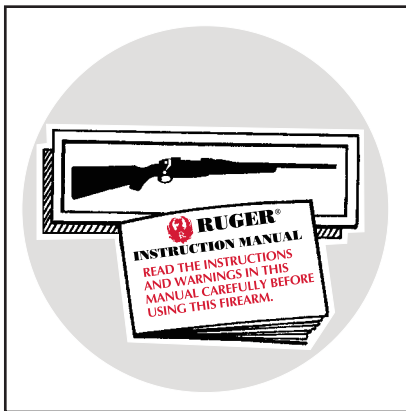

varies in accordance with the mechanical provisions for avoiding accidental discharge and the various proper procedures for loading and unloading. No person should handle any firearm without first having thoroughly familiarized himself with the particular type of firearm he is using, and with safe gun handling in general.

2. ALWAYS KEEP THE MUZZLE POINTED IN A SAFE DIRECTION.



Be sure of the bullet stop behind your target, even when dry-firing. Never let the muzzle of a firearm point at any part of your body or at another person. This is particularly important when loading or unloading a firearm. In the event of an accidental discharge, no injury can occur as long as the muzzle is pointing in a safe direction. A safe direction means a direction that will not permit a discharged bullet to strike a person, or to strike an object from which the bullet may ricochet.

A safe direction must take into account the fact that a bullet may penetrate a wall, ceiling, floor, window, etc., and strike a person or damage property. Make it a habit to know exactly where the muzzle of your gun is pointing whenever you handle it, and be sure that you are always in control of the direction in which the muzzle is pointing, even if you fall or stumble. Keep your finger off the trigger until you are ready to shoot.

3. FIREARMS SHOULD BE UNLOADED WHEN NOT IN USE.

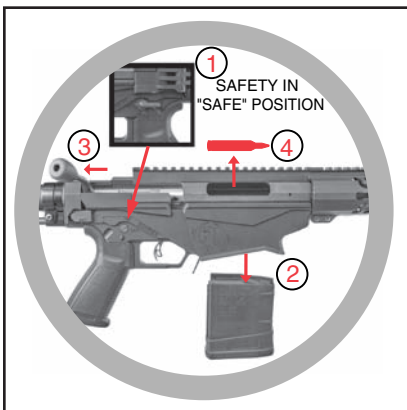

Firearms should be loaded only when you are in the field or on the target range or shooting area, ready to shoot. Firearms and ammunition should be securely locked in safes, racks or cabinets, or by using the locking device supplied with the firearm, when not in use. Ammunition should safely be stored separate from firearms. Store your firearms out of sight of visitors and children. It is the gun owner's responsibility to be certain that children and

persons unfamiliar with firearms cannot gain access to firearms, ammunition, or components.

4. BE SURE THE BARREL IS CLEAR OF OBSTRUCTIONS BEFORE SHOOTING.

Even a bit of mud, snow or excess lubricating oil or grease in the bore may cause the barrel to bulge, or even burst on firing, and can cause serious injury to the shooter and bystanders. Be sure that you are using ammunition of the proper caliber and loading for the gun you are using. If the report or recoil on firing seems weak, or doesn't seem quite right, **CEASE FIRING IMMEDIATELY**, unload your firearm, and check to be sure that no obstruction has become lodged in the barrel. Never try to shoot out an obstruction!

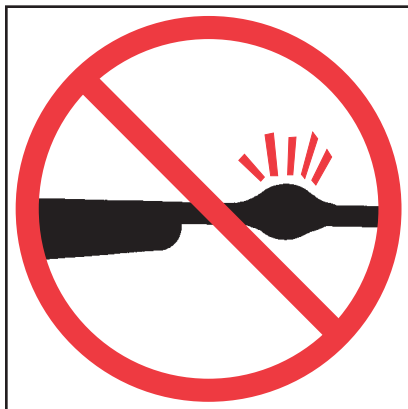



5. BE SURE OF YOUR TARGET BEFORE YOU SHOOT.

Don't shoot unless you know exactly where your bullet is going to strike. Be sure of the bullet stop behind your target, even when dry-firing with an unloaded gun. If you are in the field hunting, do not fire at a movement or noise. Take the time to be absolutely certain of your target before you pull the trigger.

6. WEAR SHOOTING GLASSES AND HEARING PROTECTION WHEN YOU SHOOT.

All shooters should wear protective shooting glasses and adequate hearing protection when shooting. Exposure to shooting noise can damage hearing, and wearing adequate eye protection when shooting is essential.



7. NEVER CLIMB A TREE



OR FENCE WITH A LOADED FIREARM.

Put the firearm down carefully before climbing a fence, and unload it before climbing or descending a tree or jumping over a ditch or other obstruction. Never pull or push a loaded firearm toward yourself or another person. When in doubt, or whenever you are about to do anything awkward, unload your gun!

8. DON'T SHOOT AT A HARD SURFACE OR AT WATER.

Bullets can glance off many surfaces like rocks or the surface of water and travel in unpredictable directions with considerable velocity.



9. NEVER TRANSPORT A LOADED FIREARM.

Firearms should always be unloaded before being placed in a vehicle. A suitable carrying case or scabbard should be used to carry an unloaded firearm to and from the shooting area.

10. AVOID ALCOHOLIC BEVERAGES WHEN SHOOTING.

Don't drink until the day's shooting is over. Handling firearms while under the influence of alcohol in any form, or medications that could affect your judgement or coordination, constitutes a criminal disregard for the safety of others.



A BRIEF ACCOUNT OF AN EXTRAORDINARY ACHIEVEMENT: RUGER® FIREARMS

Sturm, Ruger & Company, Inc., had its beginning in a small machine shop occupying a rented frame building in Southport, Connecticut. In January, 1949, with an initial investment of only \$50,000 and an idea, William B. Ruger and Alexander M. Sturm started production of a .22 caliber autoloading pistol—a design which was so successful that it became the cornerstone upon which one of the most comprehensive lines of sporting firearms ever made in America was established. After Alex Sturm's death in 1951, William B. Ruger continued to direct the Company until his death in 2002. William B. Ruger, Jr. continued to provide guidance, which helped make this Company a sound and successful enterprise, until his retirement in 2006. The Company has continued to prosper, under new management and guidance from our Board, with new products and fresh perspectives.

Ruger, in this relatively short time, has established itself as a leading small arms design organization, developing a unique and broad line of fine quality sporting, military and police firearms to become one of the world's most famous producers of revolvers, pistols, rifles and shotguns. Since 1949, Ruger craftsmen have built many millions of firearms.

During its five decades of growth and progress under the leadership of William B. Ruger, the Company developed a business philosophy and implemented policies which represent a constructive influence in the life of modern America. From the beginning, Ruger played a positive role in conservation efforts and has supported the interests of shooters through such groups as the National Rifle Association, National Shooting Sports Foundation, and many regional sportsmen's organizations.

The Company has always endeavored to market its firearms for constructive and recreational purposes, to emphasize the traditional and responsible aspects of shooting, to render meaningful public services, and to encourage shooters in constructive, responsible, and safe participation in the shooting sports. Its motto, "Arms Makers For Responsible Citizens®," exemplifies this Company philosophy.

Today, Ruger® is particularly mindful of those elements which have contributed to the creation of its success, and extends heartfelt thanks to its many loyal employees and customers.

The firearms catalog, and instruction manuals for all Ruger® firearms, can be downloaded from our website at:

www.ruger.com

WHY NO WARRANTY CARD HAS BEEN PACKED WITH THIS NEW RUGER® FIREARM

The Magnuson-Moss Act (Public Law 93-637) does not require any seller or manufacturer of a consumer product to give a written warranty. It does provide that if a written warranty is given, it must be designated as "limited" or as "full" and sets minimum standards for a "full" warranty. Sturm, Ruger & Company, Inc. has elected not to provide any written warranty, either "limited" or "full", rather than to attempt to comply with the provisions of the Magnuson-Moss Act and the regulations issued thereunder. There are certain implied warranties under state law with respect to sales of consumer goods. As the extent and interpretation of these implied warranties varies from state to state, you should refer to your state statutes. Sturm, Ruger & Company wishes to assure its customers of its continued interest in providing service to owners of Ruger® firearms.



STURM, RUGER & COMPANY, INC.
411 Sunapee Street
Newport, New Hampshire 03773 U.S.A.
www.ruger.com

Arms Makers For Responsible Citizens®

**A COPY OF THE INSTRUCTION MANUAL FOR ANY RUGER®
FIREARM IS AVAILABLE FROM THE FACTORY FREE ON REQUEST, OR IT MAY BE
DOWNLOADED FROM OUR WEBSITE AT WWW.RUGER.COM.**

**THESE INSTRUCTION MANUALS CONTAIN IMPORTANT
WARNINGS WHICH MUST BE UNDERSTOOD
BEFORE USING THESE FIREARMS.**

The Following are Sturm, Ruger & Co., Inc. Trademarks: "BX-Trigger," "Bisley," Eagle "SR," "Elite 452," "Gold Label," "It's Mine and It's American," "LC6," "LCR-357," "LCRx," "Mark II," "Mark III," "Match Champion," "Model 96," "P345D," "P345PR," "P85," "P90," "P91," "P93," "P94," "P95," "P97," "Ruger Marksman Adjustable," "Ruger 77/50," "Ruger 10/17," "77/357," "Single-Seven," "SR45," "SR-556C," "SR-556VT," "SR-762," "10/22-FS," "22 Charger," "22/45," and "22/45 RP."

The Following are Registered U.S. Trademarks Belonging to Sturm, Ruger & Co., Inc.: "RUGER," Sturm, Ruger Logo, "AC-556," "AR-556," "Arms Makers For Responsible Citizens," "All-Weather," "Bearcat," "Blackhawk," "BX-15," "BX-25," Eagle "R," "GP100," Hard "R" Logo, "Hawkeye," "LC380," "LC9," "LC9s," "LCP," "LCR," "M77," "Mini Thirty," "Mini-14," "9E," "Old Army," "Power Bedding," "P345," "Redhawk," "Ruger American Rifle," "Ruger American Rimfire," "Ruger Hunting," "Ruger Hunting" Logo, "Ruger Inside & Out" phrase & logo design, "Ruger 77/17," "Ruger 77/22," "Ruger 77/44," "Ruger SP101," "Ruger 10/22 Takedown" phrase & logo design, "Ruger Titanium," "Ruger 22/45 Lite," "Ruger Vaquero," "Rugged, Reliable Firearms," "Security-Six," "Service-Six," "Single-Nine," "Single-Six," "Single-Ten," "Speed-Six," the "SR" Design, "SR9," "SR9c," "SR40," "SR40c," "SR-22," "SR22," "SR-556," "SR-556E," "SR1911," "Super Redhawk Alaskan," "Target Grey," "10/22," and "10/22 Takedown."